

EAT•N

Weatherhead

Crimp Specifications Manual

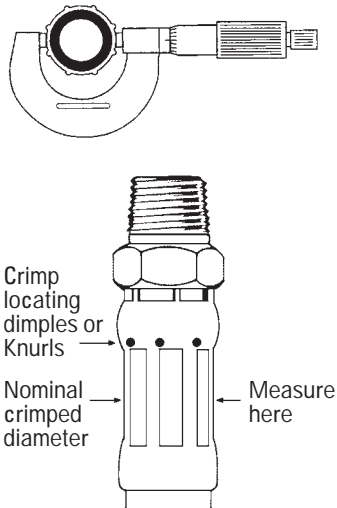

Table of Contents

Tooling Selector Chart Description	Page
T-400-1, T-400-17, T-407-1, T-460, T-462, T-465	3
T-420	11
T-480	19
T-410	27
T-440	36
T-475	45
ET1000	46
Eaton's Weatherhead Hose and Fitting Assembly Product Warning	51

Tooling Selector Chart

T-400-1, T-400-17,
T-407-1, T-460,
T-462, T-465



Note:

In larger sizes, calipers may be used; however, in smaller sizes, and in the 'E' Series thermoplastic hose ends, a point micrometer will provide an accurate reading. Nominal crimp diameters are for Weatherhead hose and end fittings when crimped with Weatherhead Coll-O-Crimp tooling.

⚠ WARNING

Proper Selection of Hose Ends: Selection of the proper end fittings for the hose end application is essential to the proper operation and safe use of the hose and related equipment. Inadequate attention to the selection of the end fittings for your application can result in leaking or the hose ends blowing off the hose, leading to serious bodily injury or property damage. In order to avoid serious bodily injury or property damage resulting from selection of the wrong end fitting, you should carefully review the information in the Weatherhead Catalog W-HYOV-MC002-E.

⚠ WARNING

Coll-O-Crimp Hose, Hose Fittings and Assembly Equipment Compatibility: The Coll-O-Crimp Equipment

Package, Coll-O-Crimp End Fittings, and Coll-O-Crimp Hose have been engineered and designed as a complete hose assembly system. Each component of the Coll-O-Crimp hose assembly system is compatible with other Coll-O-Crimp components to which it relates. Component compatibility, along with the use of quality components, insures the production of reliable hose assemblies when assembled properly. The use or intermixing of fittings and hose not specifically engineered and designed for use with each other and Coll-O-Crimp equipment is not recommended and may result in the production of unsafe or unreliable hose assemblies. This can result in hose assembly leakage, hose separation or other failures which can cause serious bodily injury or property damage from spraying

fluids, flying projectiles, or other substances. Eaton's Weatherhead warranty is limited to apply only when Coll-O-Crimp end fittings and compatible Coll-O-Crimp hose are used with Coll-O-Crimp assembly equipment. **Nominal Crimp Diameter Measurement:** Please remove this chart and place near your Coll-O-Crimp equipment for reference. Measuring crimp diameters should be a part of the normal hose assembly procedure. To insure a proper crimp diameter reading, follow these steps.

1. Measure the diameter in the middle of crimped portion of the hose end.
2. Place the caliper in a position to allow a measurement across the pressed (flat) portion of the crimp.
3. See crimp diameters on following chart.

T-400-1, T-400-17,
T-407-1, T-460,
T-462, T-465

HOSE TYPE	HOSE I.D. (IN.)	SKIVE TOOL	HOSE END PREFIX	COLLET PART #	SPACER RING COLOR	SPACER RING PART #	FLAT SIDE UP/DN	NOMINAL CRIMP DIA. (IN.)
H00905	5/16	N/R	05 'E'	T-400-32C	Black	T-400-10	UP	.585
H00906	3/8	N/R	06 'E'	T-400-33C	Black	T-400-10	UP	.655
H00908	1/2	N/R	08 'E'	T-400-34C	Black	T-400-10	UP	.805
H01704	1/4	N/R	04 'U'	T-400-2C	Yellow	T-400-62	UP	.580
H01706	3/8	N/R	06 'U'	T-400-3C	Black	T-400-10	UP	.785
H01708	1/2	N/R	08 'U'	T-400-4C	Silver	T-400-11	UP	.940
H01712	3/4	N/R	12 'U'	T-400-5C	Silver	T-400-11	UP	1.235
H01716	1	N/R	16 'U'	T-400-6C	Silver	T-400-11	UP	1.525
H01720	1-1/4	N/R	20 'U'	T-400-12	Black	T-400-10	DN	1.785
H03912	3/4	N/R	12 'S'	T-400-5C	Silver	T-400-11	UP	1.230
	3/4	N/R	12 'U'	T-400-5C	Silver	T-400-11	UP	1.230
H03916	1	N/R	16 'S'	T-400-6C	Silver	T-400-11	UP	1.520
	1	N/R	16 'U'	T-400-6C	Silver	T-400-11	UP	1.520
H03920	1-1/4	N/R	20 'S'	T-400-12	Black	T-400-10	DN	1.790
	1-1/4	N/R	20 'U'	T-400-12	Black	T-400-10	DN	1.790
H05904	3/16	N/R	06904 'E'	T-400-54C	Yellow	T-400-62	UP	.525
	3/16	N/R	22904 'P'	T-400-80C	Black	T-400-10	DN	.480
H05905	1/4	N/R	06905 'E'	T-400-55C	Black	T-400-10	UP	.585
H05906	5/16	N/R	06906 'E'	T-400-56C	Black	T-400-10	UP	.680

* Collet sits into two base halves, part number T-400BH and/or ET400AR-001.

Qualified on T-400 machine only.

BK=Black BU=Blue OR=Orange
RD=Red TN=Tan WH=White
YW=Yellow SV=Silver MG=Magenta
GY=Gray GR=Green BR=Brown

Tooling Selector Chart

T-400-1, T-400-17,
T-407-1, T-460,
T-462, T-465

HOSE TYPE	HOSE I.D. (IN.)	SKIVE TOOL	HOSE END PREFIX	COLLET PART #	SPACER RING COLOR	SPACER RING PART #	FLAT SIDE UP/DN	NOMINAL CRIMP DIA. (IN.)
	5/16	N/R	22906 'P'	T-400-81C	Black	T-400-10	DN	.650
H05908	13/32	N/R	06908 'E'	T-400-57C	Yellow	T-400-62	UP	.765
	13/32	N/R	22908 'P'	T-400-82C	Black	T-400-10	DN	.775
H05910	1/2	N/R	06910 'E'	T-400-58C	Black	T-400-10	UP	.910
	1/2	N/R	22910 'P'	T-400-83C	Black	T-400-10	DN	.875
H05912	5/8	N/R	06912 'E'	T-400-59C	Silver	T-400-11	UP	1.080
H05916	7/8	N/R	06916 'E'	T-400-60C	Black	T-400-10	UP	1.275
H06904	3/16	N/R	06904 'E'	T-400-54C	Yellow	T-400-62	UP	.525
H06905	1/4	N/R	06905 'E'	T-400-55C	Black	T-400-10	UP	.585
H06906	5/16	N/R	06906 'E'	T-400-56C	Black	T-400-10	UP	.680
H06908	13/32	N/R	06908 'E'	T-400-57C	Yellow	T-400-62	UP	.765
H06910	1/2	N/R	06910 'E'	T-400-58C	Black	T-400-10	UP	.910
H06912	5/8	N/R	06912 'E'	T-400-59C	Silver	T-400-11	UP	1.080
H06916	7/8	N/R	06916 'E'	T-400-60C	Black	T-400-10	UP	1.275
H06920	1-1/8	N/R	06920 'E'	T-400-61C	Yellow	T-400-62	UP	1.520
H06924	1-3/8	N/R	06924 'E'	T-400-70	Black	T-400-10	UP	1.730
H10404	1/4	N/R	04 'S'	T-400-2C	Black	T-400-10	DN	.561
	1/4	N/R	04 'U'	T-400-2C	Black	T-400-10	DN	.560
	1/4	N/R	04 'W'	T-400-40C	Black	T-400-10	DN	.664
	1/4	N/R	04 'Z'	ET400DC-M150S	Purple	ET1000SR-M100A	UP	.620
H10406	3/8	N/R	06 'S'	T-400-3C	Black	T-400-10	DN	.740
	3/8	N/R	06 'U'	T-400-3C	Black	T-400-10	DN	.740
	3/8	N/R	06 'W'	T-400-41C	Black	T-400-10	DN	.820
	3/8	N/R	06 'Z'	ET400DC-M195S	Purple	ET1000SR-M100A	UP	.785
H10408	1/2	N/R	08 'S'	T-400-4C	Black	T-400-10	DN	.863
	1/2	N/R	08 'U'	T-400-4C	Black	T-400-10	DN	.870
	1/2	N/R	08 'W'	T-400-42C	Black	T-400-10	DN	.976
	1/2	N/R	08 'Z'	ET400DC-M230S	Black	T-400-10	DN	.940
H10410	5/8	N/R	10 'U'	T-400-64C	Black	T-400-10	DN	1.000
	5/8	N/R	10 'W'	T-400-43C*	N/R	N/R	N/R	1.132
	5/8	N/R	10 'Z'	ET400DC-M245S*	N/A	N/A	N/A	1.055
H10412	3/4	N/R	12 'S'	T-400-5C	Yellow	T-400-62	UP	1.177
	3/4	N/R	12 'U'	T-400-5C	Black	T-400-10	DN	1.160
	3/4	N/R	12 'W'	T-400-44C*	N/R	N/R	N/R	1.260
	3/4	N/R	12 'Z'	ET400DC-M295S*	N/A	N/A	N/A	1.250
H10416	1	N/R	16 'S'	T-400-6C	Yellow	T-400-62	UP	1.465
	1	N/R	16 'U'	T-400-6C	Black	T-400-10	DN	1.450
	1	N/R	16 'Z'	ET400DC-M375S*	BK/GR#	ET400SR-002	N/A	1.590
H10420	1-1/4	N/R	20 'S'	T-400-12	Black	T-400-10	DN	1.790
	1-1/4	N/R	20 'U'	T-400-12	Black	T-400-10	DN	1.785
H10504	1/4	N/R	04 'U'	T-400-2C	Black	T-400-10	UP	.610
H10506	3/8	N/R	06 'U'	T-400-3C	Black	T-400-10	UP	.788
H10508	1/2	N/R	08 'U'	T-400-4C	Silver	T-400-11	UP	.940
H10512	3/4	N/R	12 'U'	T-400-5C	Silver	T-400-11	UP	1.232
H10516	1	N/R	16 'U'	T-400-6C	Silver	T-400-11	DN	1.435
H11404	1/4	N/R	04 'S'	T-400-2C	Green	T-400-37	UP	.520
	1/4	N/R	04 'U'	T-400-2C	Green	T-400-37	UP	.520
H11406	3/8	N/R	06 'S'	T-400-3C	Green	T-400-37	UP	.695
	3/8	N/R	06 'U'	T-400-3C	Green	T-400-37	UP	.695
H11408	1/2	N/R	08 'S'	T-400-4C	Black	T-400-10	DN	.860
	1/2	N/R	08 'U'	T-400-4C	Green	T-400-37	UP	.830
H11504	1/4	N/R	04 'U'	T-400-2C	Black	T-400-10	UP	.610
H11506	3/8	N/R	06 'U'	T-400-3C	Black	T-400-10	UP	.788
H11508	1/2	N/R	08 'U'	T-400-4C	Silver	T-400-11	UP	.940
H11512	3/4	N/R	12 'U'	T-400-5C	Silver	T-400-11	UP	1.232
H11516	1	N/R	16 'U'	T-400-6C	Silver	T-400-11	UP	1.522

* Collet sits into two base halves, part number T-400BH and/or ET400AR-001.
Qualified on T-400 machine only.

BK=Black **BU**=Blue **OR**=Orange
RD=Red **TN**=Tan **WH**=White
YW=Yellow **SV**=Silver **MG**=Magenta
GY=Gray **GR**=Green **BR**=Brown

Tooling Selector Chart

T-400-1, T-400-17,
T-407-1, T-460,
T-462, T-465

HOSE TYPE	HOSE I.D. (IN.)	SKIVE TOOL	HOSE END PREFIX	COLLET PART #	SPACER RING COLOR	SPACER RING PART #	FLAT SIDE UP/DN	NOMINAL CRIMP DIA. (IN.)
H11520	1-1/4	N/R	20 'U'	T-400-12	Silver	T-400-11	UP	1.862
H14504	1/4	N/R	04 'M'	T-400-109C	Yellow	T-400-62	UP	.630
H14504	1/4	N/R	04 'S'	T-400-2C	Green	T-400-37	UP	.520
	1/4	N/R	04 'U'	T-400-2C	Green	T-400-37	UP	.520
	1/4	N/R	04 'W'	T-400-40C	BK/TN	T-400-46R	UP	.678
	1/4	N/R	04 'Z'	ET400DC-M150S	Purple	ET1000SR-M100A	UP	0.612
H145R04	1/4	N/R	04 'Z'	ET400DC-M150S	Purple	ET1000SR-M100A	UP	.612
H14506	3/8	N/R	06 'M'	T-400-110C	Yellow	T-400-62	UP	.765
	3/8	N/R	06 'S'	T-400-3C	Green	T-400-37	UP	.695
	3/8	N/R	06 'U'	T-400-3C	Green	T-400-37	UP	.695
	3/8	N/R	06 'W'	T-400-41C	Green	T-400-37	UP	.782
	3/8	N/R	06 'Z'	ET400DC-M195S	Green	T-400-37	UP	.775
H145R06	3/8	N/R	06 'Z'	ET400DC-M195S	Green	T-400-37	UP	.775
H14508	1/2	N/R	08 'M'	T-400-111C	Yellow	T-400-62	UP	.935
	1/2	N/R	08 'S'	T-400-4C	Yellow	T-400-62	DN	.870
	1/2	N/R	08 'U'	T-400-4C	Yellow	T-400-62	DN	.870
	1/2	N/R	08 'W'	T-400-42C	Black	T-400-10	DN	.976
	1/2	N/R	08 'Z'	ET400DC-M230S	Purple	ET1000SR-M100A	UP	.920
H145R08	1/2	N/R	08 'Z'	ET400DC-M230S	Purple	ET1000SR-M100A	UP	.920
H14510	5/8	N/R	10 'U'	T-400-64C	Yellow	T-400-62	UP	1.010
	5/8	N/R	10 'W'	T-400-43C*	BK/YW#	T-400-45R	N/A	1.149
	5/8	N/R	10 'Z'	ET400DC-M245S*	BK/SV#	T-400-49R	N/A	1.115
H145R10	5/8	N/R	10 'Z'	ET400DC-M245S*	BK/SV	T-400-49R	N/A	1.115
H14512	3/4	N/R	12 'S'	T-400-5C	Yellow	T-400-62	DN	1.160
	3/4	N/R	12 'U'	T-400-5C	Yellow	T-400-62	DN	1.160
	3/4	N/R	12 'W'	T-400-44C*	BK/OR#	T-400-48R	N/A	1.293
	3/4	N/R	12 'Z'	ET400DC-M295S*	BK/GR#	ET400SR-002	N/A	1.275
H145R12	3/4	N/R	12 'Z'	ET400DC-M295S*	BK/GR#	ET400SR-002	N/A	1.275
H14516	1	N/R	16 'S'	T-400-6C	Yellow	T-400-62	DN	1.445
	1	N/R	16 'Z'	ET400DC-M375S*	BK/PU#	ET400SR-003	N/A	1.575
H145R16	1	N/R	16 'Z'	ET400DC-M375S*	BK/PU#	ET400SR-003	N/A	1.575
H14604	1/4	N/R	04 'U'	T-400-2C	Green	T-400-37	UP	.520
H14606	3/8	N/R	06 'U'	T-400-3C	Green	T-400-37	UP	.695
H14608	1/2	N/R	08 'U'	T-400-4C	Green	T-400-37	UP	.830
H16604	3/16	N/R	06904 'E'	T-400-54C	Yellow	T-400-62	UP	.525
H16605	1/4	N/R	06905 'E'	T-400-55C	Black	T-400-10	UP	.585
H16606	5/16	N/R	06906 'E'	T-400-56C	Black	T-400-10	UP	.680
H16608	13/32	N/R	06908 'E'	T-400-57C	Yellow	T-400-62	UP	.765
H16610	1/2	N/R	06910 'E'	T-400-58C	Black	T-400-10	UP	.910
H16612	5/8	N/R	06912 'E'	T-400-59C	Silver	T-400-11	UP	1.080
H16616	7/8	N/R	06916 'E'	T-400-60C	Black	T-400-10	UP	1.275
H16620	1-1/8	N/R	06920 'E'	T-400-61C	Yellow	T-400-62	UP	1.520
H16904	3/16	N/R	06904 'E'	T-400-54C	Yellow	T-400-62	UP	.525
H16905	1/4	N/R	06905 'E'	T-400-55C	Black	T-400-10	UP	.585
H16906	5/16	N/R	06906 'E'	T-400-56C	Black	T-400-10	UP	.680
H16908	13/32	N/R	06908 'E'	T-400-57C	Yellow	T-400-62	UP	.765
H16910	1/2	N/R	06910 'E'	T-400-58C	Black	T-400-10	UP	.910
H16912	5/8	N/R	06912 'E'	T-400-59C	Silver	T-400-11	UP	1.080
H16916	7/8	N/R	06916 'E'	T-400-60C	Black	T-400-10	UP	1.275
H16920	1-1/8	N/R	06920 'E'	T-400-61C	Yellow	T-400-62	UP	1.520
H16924	1-3/8	N/R	06924 'E'	T-400-70	Black	T-400-10	UP	1.730
H19004	1/4	N/R	04 'W'	T-400-40C	Black	T-400-10	DN	.664
	1/4	N/R	04 'Z'	ET400DC-M150S	Purple	ET1000SR-M100A	UP	0.620
H190H04	1/4	N/R	04 'Z'	ET400DC-M150S	Purple	ET1000SR-M100A	UP	0.620
H19006	3/8	N/R	06 'W'	T-400-41C	Black	T-400-10	DN	.820
	3/8	N/R	06 'Z'	ET400DC-M195S	Green	T-400-37	UP	0.770

* Collet sits into two base halves, part number T-400BH and/or ET400AR-001.

Qualified on T-400 machine only.

Spacer Ring is Flat on both sides
Fits between two halves of T-400BH

BK=Black **BU**=Blue **OR**=Orange
RD=Red **TN**=Tan **WH**=White
YW=Yellow **SV**=Silver **MG**=Magenta
GY=Gray **GR**=Green **BR**=Brown

Tooling Selector Chart

T-400-1, T-400-17,
T-407-1, T-460,
T-462, T-465

HOSE TYPE	HOSE I.D. (IN.)	SKIVE TOOL	HOSE END PREFIX	COLLET PART #	SPACER RING COLOR	SPACER RING PART #	FLAT SIDE UP/DN	NOMINAL CRIMP DIA. (IN.)
H190H06	3/8	N/R	06 'Z'	ET400DC-M195S	Green	T-400-37	UP	0.770
H19008	1/2	N/R	08 'W'	T-400-42C	Black	T-400-10	DN	.976
	1/2	N/R	08 'Z'	ET400DC-M230S	Black	T-400-10	DN	0.940
H190H08	1/2	N/R	08 'Z'	ET400DC-M230S	Black	T-400-10	DN	0.940
H19010	5/8	N/R	10 'W'	T-400-43C*	N/R	N/R	N/R	1.132
	5/8	N/R	10 'Z'	ET400DC-M245S*	N/R	N/R	N/R	1.055
H190H10	5/8	N/R	10 'Z'	ET400DC-M295S	N/R	N/R	N/R	1.055
H19012	3/4	N/R	12 'W'	T-400-44C*	N/R	N/R	N/R	1.260
	3/4	N/R	12 'Z'	ET400DC-M295S*	Brown	ET420SR-M495A	UP	1.250
H190H12	3/4	N/R	12 'Z'	T-420-86C	Brown	ET420SR-M495A	UP	1.250
H19016	1	N/R	16 'Z'	ET400DC-M375S*	BK/GR#	T420-29	UP	1.590
H190H16	1	N/R	16 'Z'	ET400DC-M375S	BK/GR	T-420-29	UP	1.590
H20904	1/4	N/R	04 'E'	T-400-31C	Black	T-400-10	DN	.455
H20905	5/16	N/R	05 'E'	T-400-32C	Black	T-400-10	DN	.555
H20906	3/8	N/R	06 'E'	T-400-33C	Black	T-400-10	DN	.615
H20908	1/2	N/R	08 'E'	T-400-34C	Black	T-400-10	DN	.765
H22904	3/16	N/R	06904 'E'	T-400-54C	Yellow	T-400-62	UP	.525
	3/16	N/R	22904 'P'	T-400-80C	Yellow	T-400-62	UP	.505
H22906	5/16	N/R	06906 'E'	T-400-56C	Black	T-400-10	UP	.680
	5/16	N/R	22906 'P'	T-400-81C	Black	T-400-10	DN	.650
H22908	13/32	N/R	06908 'E'	T-400-57C	Yellow	T-400-62	UP	.765
	13/32	N/R	22908 'P'	T-400-82C	Black	T-400-10	DN	.775
H22910	1/2	N/R	06910 'E'	T-400-58C	Black	T-400-10	UP	.910
	1/2	N/R	22910 'P'	T-400-83C	Black	T-400-10	DN	.875
H22912	5/8	N/R	06912 'E'	T-400-59C	Silver	T-400-11	UP	1.080
H22916	7/8	N/R	06916 'E'	T-400-60C	Black	T-400-10	UP	1.275
H23904	3/16	N/R	069 'E'	T-400-54C	Yellow	T-400-62	UP	.525
	3/16	N/R	229 'P'	T-400-80C	Black	T-400-10	DN	.480
H23906	5/16	N/R	069 'E'	T-400-56C	Black	T-400-10	UP	.680
	5/16	N/R	229 'P'	T-400-81C	Black	T-400-10	DN	.650
H23908	13/32	N/R	069 'E'	T-400-57C	Yellow	T-400-62	UP	.765
	13/32	N/R	229 'P'	T-400-82C	Black	T-400-10	DN	.775
H23910	1/2	N/R	069 'E'	T-400-58C	Black	T-400-10	UP	.910
	1/2	N/R	229 'P'	T-400-83C	Black	T-400-10	DN	.875
H23912	5/8	N/R	069 'E'	T-400-59C	Silver	T-400-11	UP	1.080
H23916	7/8	N/R	069 'E'	T-400-60C	Black	T-400-10	UP	1.275
H23920	1-1/8	N/R	069 'E'	T-400-61C	Yellow	T-400-62	UP	1.510
H24303	3/16	N/R	03 'E'	T-400-113C	Tan	T-400-112	UP	.355
H24304	1/4	N/R	04 'E'	T-400-31C	Green	T-400-37	UP	.405
H24305	5/16	N/R	05 'E'	T-400-32C	Red	T-400-38	UP	.475
H24306	3/8	N/R	06 'E'	T-400-33C	Red	T-400-38	UP	.545
H24308	1/2	N/R	08 'E'	T-400-34C	Red	T-400-38	UP	.695
H24312	3/4	N/R	12 'E'	T-400-35C	Red	T-400-38	UP	.978
H24316	1	N/R	16 'E'	T-400-36C	Red	T-400-38	UP	1.225
H24504	1/4	N/R	04 'M'	T-400-109C	Black	T-400-10	UP	.665
	1/4	N/R	04 'S'	T-400-2C	Yellow	T-400-62	DN	.560
	1/4	N/R	04 'U'	T-400-2C	Yellow	T-400-62	DN	.560
	1/4	N/R	04 'W'	T-400-40C	BK/TN	T-400-46R	UP	.678
	1/4	N/R	04 'Z'	ET400DC-M150S	Black	T-400-10	DN	.650
H245L04	1/4	N/R	04 'Z'	ET400DC-M150S	Black	T-400-10	DN	.640
H24506	3/8	N/R	06 'M'	T-400-110C	Black	T-400-10	UP	.805
	3/8	N/R	06 'S'	T-400-3C	Yellow	T-400-62	DN	.740
	3/8	N/R	06 'U'	T-400-3C	Yellow	T-400-62	DN	.740
	3/8	N/R	06 'W'	T-400-41C	Black	T-400-10	DN	.820
	3/8	N/R	06 'Z'	ET400DC-M195S	Tan	T-400-112	UP	.800
H245L06	3/8	N/R	06 'Z'	ET400DC-M195S	Tan	T-400-112	UP	.800

* Collet sits into two base halves, part number T-400BH and/or ET400AR-001.

Qualified on T-400 machine only.

Spacer Ring is Flat on both sides
Fits between two halves of T-400BH

BK=Black **BU**=Blue **OR**=Orange
RD=Red **TN**=Tan **WH**=White
YW=Yellow **SV**=Silver **MG**=Magenta
GY=Gray **GR**=Green **BR**=Brown

Tooling Selector Chart

T-400-1, T-400-17,
T-407-1, T-460,
T-462, T-465

HOSE TYPE	HOSE I.D. (IN.)	SKIVE TOOL	HOSE END PREFIX	COLLET PART #	SPACER RING COLOR	SPACER RING PART #	FLAT SIDE UP/DN	NOMINAL CRIMP DIA. (IN.)
H24508	1/2	N/R	08 'M'	T-400-111C	Yellow	T-400-62	UP	.940
	1/2	N/R	08 'S'	T-400-4C	Yellow	T-400-62	DN	.865
	1/2	N/R	08 'U'	T-400-4C	Yellow	T-400-62	DN	.865
	1/2	N/R	08 'W'	T-400-42C	BK/TN	T-400-46R	UP	.993
	1/2	N/R	08 'Z'	ET400DC-M230S	Lt. Green	ET1000SR-M190D	UP	.975
H245L08	1/2	N/R	08 'Z'	ET400DC-M230S	Lt Green	ET1000SR-M190D	UP	.975
H24510	5/8	N/R	10 'U'	T-400-64C	Yellow	T-400-62	UP	1.010
	5/8	N/R	10 'W'	T-400-43C*	N/R	N/R	N/R	1.132
	5/8	N/R	10 'Z'	ET400DC-M245S*	BK/SV#	T-400-49R	N/A	1.115
H245L10	5/8	N/R	10 'Z'	ET400DC-M245S	BK/SV	T-400-49R	N/A	1.115
H24512	3/4	N/R	12 'S'	T-400-5C	Yellow	T-400-62	DN	1.160
	3/4	N/R	12 'U'	T-400-5C	Yellow	T-400-62	DN	1.160
	3/4	N/R	12 'W'	T-400-44C*	BK/OR#	T-400-48R	N/A	1.293
	3/4	N/R	12 'Z'	ET400DC-M295S*	N/R	N/R	N/R	1.245
H245L12	3/4	N/R	12 'Z'	ET400DC-M295S	N/R	N/R	N/R	1.245
H24516	1	N/R	16 'S'	T-400-6C	Yellow	T-400-62	UP	1.465
H24516	1	N/R	16 'U'	T-400-6C	Yellow	T-400-62	UP	1.465
	1	N/R	16 'Z'	ET400DC-M375S*	N/R	N/R	N/R	1.565
H245L16	1	N/R	16 'Z'	ET400DC-M375S	N/R	N/R	N/R	1.565
H24520	1-1/4	N/R	20 'S'	T-400-12	Yellow	T-400-62	DN	1.795
	1-1/4	N/R	20 'U'	T-400-12	Yellow	T-400-62	DN	1.795
H26504	1/4	N/R	26504 'P'	T-400-2C	Green	T-400-37	UP	.520
H26506	3/8	N/R	06 'E'	T-400-33C	Black	T-400-10	UP	.660
	3/8	N/R	26506 'P'	T-400-2C	Silver	T-400-11	UP	.640
H26508	1/2	N/R	08 'E'	T-400-34C	Black	T-400-10	UP	.810
	1/2	N/R	26508 'P'	T-400-3C	Black	T-400-10	UP	.788
H26512	3/4	N/R	12 'E'	T-400-35C	Black	T-400-10	UP	1.090
	3/4	N/R	26512 'P'	T-400-64C	Silver	T-400-11	UP	1.070
H26516	1	N/R	16 'E'	T-400-36C	Black	T-400-10	UP	1.340
H27504	1/4	N/R	26504 'P'	T-400-2C	Green	T-400-37	UP	.520
H27506	3/8	N/R	06 'E'	T-400-33C	Black	T-400-10	UP	.660
	3/8	N/R	26506 'P'	T-400-2C	Silver	T-400-11	UP	.640
H27508	1/2	N/R	08 'E'	T-400-34C	Black	T-400-10	UP	.810
	1/2	N/R	26508 'P'	T-400-3C	Black	T-400-10	UP	.788
H27512	3/4	N/R	12 'E'	T-400-35C	Black	T-400-10	UP	1.090
	3/4	N/R	26512 'P'	T-400-64C	Silver	T-400-11	UP	1.070
H27516	1	N/R	16 'E'	T-400-36C	Black	T-400-10	UP	1.340
H27703	3/16	N/R	03 'E'	T-400-113C	Tan	T-400-112	UP	.355
H27704	1/4	N/R	04 'E'	T-400-31C	Green	T-400-37	UP	.405
H27705	5/16	N/R	05 'E'	T-400-32C	Red	T-400-38	UP	.475
H27706	3/8	N/R	06 'E'	T-400-33C	Red	T-400-38	UP	.545
H27708	1/2	N/R	08 'E'	T-400-34C	Red	T-400-38	UP	.695
H27712	3/4	N/R	12 'E'	T-400-35C	Red	T-400-38	UP	.978
H27716	1	N/R	16 'E'	T-400-36C	Red	T-400-38	UP	1.225
H28004	1/4	N/R	04 'W'	T-400-40C	BK/TN	T-400-46R	UP	.678
	1/4	N/R	04 'Z'	ET400DC-M150S	Yellow	T-400-62	UP	.665
H28006	3/8	N/R	06 'W'	T-400-41C	Black	T-400-10	DN	.820
	3/8	N/R	06 'Z'	ET400DC-M195S	Black	T-400-10	DN	.815
H28008	1/2	N/R	08 'W'	T-400-42C	BK/TN	T-400-46R	UP	.992
	1/2	N/R	08 'Z'	ET400DC-M230S	Lt. Green	ET1000SR-M190D	UP	.975
H28010	5/8	N/R	10 'W'	T-400-43C*	N/R	N/R	N/R	1.132
	5/8	N/R	10 'Z'	ET400DC-M245S*	BK/SV#	T-400-49R	N/A	1.115
H28012	3/4	N/R	12 'W'	T-400-44C*	BK/OR#	T-400-48R	N/A	1.293
	3/4	N/R	12 'Z'	ET400DC-M295S*	N/A	N/A	N/A	1.245
H28016	1	N/R	16 'Z'	ET400DC-M375S*	N/A	N/A	N/A	1.565
H28504	1/4	N/R	04 'E'	T-400-31C	Black	T-400-10	UP	.500

* Collet sits into two base halves, part number T-400BH and/or ET400AR-001.

Qualified on T-400 machine only.

Spacer Ring is Flat on both sides Fits between two halves of T-400BH

BK=Black **BU**=Blue **OR**=Orange
RD=Red **TN**=Tan **WH**=White
YW=Yellow **SV**=Silver **MG**=Magenta
GY=Gray **GR**=Green **BR**=Brown

Tooling Selector Chart

T-400-1, T-400-17,
T-407-1, T-460,
T-462, T-465

HOSE TYPE	HOSE I.D. (IN.)	SKIVE TOOL	HOSE END PREFIX	COLLET PART #	SPACER RING COLOR	SPACER RING PART #	FLAT SIDE UP/DN	NOMINAL CRIMP DIA. (IN.)
	1/4	N/R	26504 'P'	T-400-2C	Green	T-400-37	UP	.520
H28506	3/8	N/R	06 'E'	T-400-33C	Black	T-400-10	UP	.660
	3/8	N/R	26506 'P'	T-400-2C	Silver	T-400-11	UP	.640
H28508	1/2	N/R	08 'E'	T-400-34C	Black	T-400-10	UP	.810
	1/2	N/R	26508 'P'	T-400-3C	Black	T-400-10	UP	.788
H28512	3/4	N/R	12 'E'	T-400-35C	Black	T-400-10	UP	1.090
	3/4	N/R	26512 'P'	T-400-64C	Silver	T-400-11	UP	1.070
H28516	1	N/R	16 'E'	T-400-36C	Black	T-400-10	UP	1.340
H29004	1/4	N/R	04 'W'	T-400-40C	Black	T-400-10	UP	.722
	1/4	N/R	04 'Z'	ET400DC-M150S	Lt. Green	ET1000SR-M190D	UP	.680
H290H04	1/4	N/R	04 'Z'	ET400DC-M150S	Lt Green	ET1000SR-M190D	UP	.680
H29006	3/8	N/R	06 'W'	T-400-41C	BK/RD	T-400-47R	UP	.854
	3/8	N/R	06 'Z'	ET400DC-M195S	Yellow	T-400-62	UP	.835
H290H06	3/8	N/R	06 'Z'	ET400DC-M195S	Yellow	T-400-62	UP	.835
H29008	1/2	N/R	08 'W'	T-400-42C	BK/RD	T-400-47R	UP	1.007
	1/2	N/R	08 'Z'	ET400DC-M230S	Black	T-400-10	UP	.990
H290H08	1/2	N/R	08 'Z'	ET400DC-M230S	Black	T-400-10	UP	.990
H29010	5/8	N/R	10 'W'	T-400-43C*	BK/YW#	T-400-45R	N/A	1.149
	5/8	N/R	10 'Z'	ET400DC-M245S*	BK/RD#	T-400-47R	N/A	1.130
H290H10	5/8	N/R	10 'Z'	ET400DC-M245S	BK/RD	T-400-47R	N/A	1.130
H29012	3/4	N/R	12 'W'	T-400-44C*	BK/SV#	T-400-49R	N/A	1.317
	3/4	N/R	12 'Z'	ET400DC-M295S*	BK/OR#	T-400-48R	Taper	1.280
H290H12	3/4	N/R	12 'Z'	ET400DC-M295S	BK/OR	T-400-48R	DbI Taper	1.280
H29016	1	N/R	16 'Z'	ET400DC-M380S*	N/R	N/R	N/A	1.640
H290H16	1	N/R	16 'Z'	ET420DC-M380S	N/R	N/R	N/R	1.640
H32406	3/8	N/R	06 'U'	T-400-3C	Black	T-400-10	UP	.785
H32504	1/4	N/R	04 'U'	T-400-2C	Black	T-400-10	UP	.610
H32506	3/8	N/R	06 'U'	T-400-3C	Black	T-400-10	UP	.795
H32508	1/2	N/R	08 'U'	T-400-4C	Yellow	T-400-62	UP	.885
H32512	3/4	N/R	12 'U'	T-400-5C	Black	T-400-10	UP	1.215
H32516	1	N/R	16 'U'	T-400-6C	Silver	T-400-11	UP	1.525
H33503	3/16	N/R	33603 'E'	T-400-120C	Black	T-400-10	UP	.540
H33504	1/4	N/R	33604 'E'	T-400-121C	Black	T-400-10	UP	.667
H33506	3/8	N/R	33606 'E'	T-400-122C	Black	T-400-10	UP	.770
H33508	1/2	N/R	33608 'E'	T-400-123C	Black	T-400-10	UP	.895
H33603	3/16	N/R	33603 'E'	T-400-120C	Black	T-400-10	UP	.540
H33604	1/4	N/R	33604 'E'	T-400-121C	Black	T-400-10	UP	.667
H33606	3/8	N/R	33606 'E'	T-400-122C	Black	T-400-10	UP	.770
H33608	1/2	N/R	33608 'E'	T-400-123C	Black	T-400-10	UP	.895
H33806	3/8	N/R	33806 'P'	T-400-102C	Black	T-400-10	DN	.700
H33808	1/2	N/R	33808 'P'	T-400-103C	Black	T-400-10	DN	.795
H34504	1/4	N/R	04 'M'	T-400-109C	Yellow	T-400-62	UP	.630
	1/4	N/R	04 'W'	T-400-40C	Black	T-400-10	DN	.664
	1/4	N/R	04 'Z'	ET400DC-M150S	Tan	T-400-112	UP	.625
H34506	3/8	N/R	06 'M'	T-400-110C	Yellow	T-400-62	UP	.765
	3/8	N/R	06 'W'	T-400-41C	Green	T-400-37	UP	.782
	3/8	N/R	06 'Z'	ET400DC-M195S	Green	T-400-37	UP	.775
H34508	1/2	N/R	08 'M'	T-400-111C	Yellow	T-400-62	DN	.915
	1/2	N/R	08 'W'	T-400-42C	Black	T-400-10	DN	.976
	1/2	N/R	08 'Z'	ET400DC-M230S	Black	T-400-10	DN	.940
H35006	3/8	N/R	06 'M'	T-400-110C	Black	T-400-10	UP	.805
	3/8	N/R	06 'W'	T-400-41C	Black	T-400-10	DN	.820
	3/8	N/R	06 'U'	T-400-3C	Yellow	T-400-62	DN	.740
	3/8	N/R	06 'Z'	ET400DC-M195S	Black	T-400-10	DN	.815
H35008	1/2	N/R	08 'M'	T-400-111C	Yellow	T-400-62	UP	.945
	1/2	N/R	08 'W'	T-400-42C	BK/TN	T-400-46R	UP	.993

* Collet sits into two base halves, part number T-400BH and/or ET400AR-001. Qualified on T-400 machine only.

Spacer Ring is Flat on both sides Fits between two halves of T-400BH

BK=Black BU=Blue OR=Orange
RD=Red TN=Tan WH=White
YW=Yellow SV=Silver MG=Magenta
GY=Gray GR=Green BR=Brown

Tooling Selector Chart

T-400-1, T-400-17,
T-407-1, T-460,
T-462, T-465

HOSE TYPE	HOSE I.D. (IN.)	SKIVE TOOL	HOSE END PREFIX	COLLET PART #	SPACER RING COLOR	SPACER RING PART #	FLAT SIDE UP/DN	NOMINAL CRIMP DIA. (IN.)
	1/2	N/R	08 'U'	T-400-4C	Yellow	T-400-62	DN	.865
	1/2	N/R	08 'Z'	ET400DC-M230S	Lt. Green	ET1000SR-M190D	UP	.975
H35010	5/8	N/R	10 'W'	T-400-43C*	N/R	N/R	N/R	1.132
H35010	5/8	N/R	10 'Z'	ET400DC-M245S*	BK/RD#	ET400SR-001	N/A	1.130
H36606	5/16	N/R	06906 'E'	T-400-56C	Black	T-400-10	UP	.680
H36608	13/32	N/R	06908 'E'	T-400-57C	Yellow	T-400-62	UP	.765
H40006	1/4	N/R	04 'Z'	ET400DC-M195S	Yellow	T-400-62	UP	.835
H40008	3/8	N/R	06 'Z'	ET400DC-M230S	Black	T-400-10	UP	.990
H40010	5/8	N/R	10 'W'	T-400-43C*	BK/YW#	T-400-45R	N/A	1.149
	5/8	N/R	10 'Z'	ET400DC-M245S*	BK/RD#	ET400SR-001	N/A	1.129
	1/2	N/R	08 'Z'	ET400DC-M245S	BK/RD#	T400-47R	N/A	1.129
H40012	3/4	N/R	12 'W'	T-400-44C*	BK/SV#	T-400-49R	N/A	1.317
	3/4	N/R	12 'Z'	ET400DC-M295S*	BK/OR#	T-400-48R	N/A	1.286
	5/8	N/R	10 'Z'	ET400DC-M295S	BK/OR#	T-400-61R	N/A	1.286
H42104	1/4	N/R	04 'Z'	ET400DC-M150S	BK/RD	T-400-47R	UP	.665
H42106	3/8	N/R	06 'Z'	ET400DC-M195S	Yellow	T-400-62	UP	.835
H42504	1/4	N/R	04 'S'	T-400-2C	Black	T-400-10	UP	.610
	1/4	N/R	04 'U'	T-400-2C	Black	T-400-10	UP	.610
	1/4	N/R	04 'W'	T-400-40C	Black	T-400-10	UP	.722
	1/4	N/R	04 'Z'	ET400DC-M150S	Yellow	T-400-62	UP	.665
H42506	3/8	N/R	06 'S'	T-400-3C	Black	T-400-10	UP	.795
	3/8	N/R	06 'U'	T-400-3C	Black	T-400-10	UP	.795
	3/8	N/R	06 'W'	T-400-41C	BK/RD	T-400-47R	UP	.854
	3/8	N/R	06 'Z'	ET400DC-M195S	Yellow	T-400-62	UP	.835
H42508	1/2	N/R	08 'S'	T-400-4C	Black	T-400-10	UP	.920
	1/2	N/R	08 'U'	T-400-4C	Black	T-400-10	UP	.915
	1/2	N/R	08 'W'	T-400-42C	BK/RD	T-400-47R	UP	1.007
	1/2	N/R	08 'Z'	ET400DC-M230S	Black	T-400-10	UP	0.990
H42510	5/8	N/R	10 'U'	T-400-64C	Black	T-400-10	UP	1.050
	5/8	N/R	10 'W'	T-400-43C*	N/R	N/R	N/R	1.132
	5/8	N/R	10 'Z'	ET400DC-M245S*	BK/RD#	ET400SR-001	N/A	1.130
H42512	3/4	N/R	12 'S'	T-400-5C	Black	T-400-10	UP	1.210
	3/4	N/R	12 'U'	T-400-5C	Black	T-400-10	UP	1.205
	3/4	N/R	12 'W'	T-400-44C*	BK/SV#	T-400-49R	N/A	1.317
	3/4	N/R	12 'Z'	ET400DC-M295S*	BK/OR#	T-400-48R	N/A	1.280
H42516	1	N/R	16 'S'	T-400-6C	Silver	T-400-11	UP	1.525
H42516	1	N/R	16 'U'	T-400-6C	Silver	T-400-11	UP	1.525
	1	N/R	16 'Z'	ET400DC-M375S*	BK/SV#	T-400-49R	N/A	1.630
H42520	1-1/4	N/R	20 'S'	T-400-12	Silver	T-400-11	UP	1.885
	1-1/4	N/R	20 'U'	T-400-12	Black	T-400-10	UP	1.850
H42908	13/32	N/R	057 'P'	T-400-102C	Green	T-400-37	UP	.660
H42910	1/2	N/R	057 'P'	T-400-103C	Green	T-400-37	UP	.750
H43504	1/4	N/R	04 'E'	T-400-31C	Black	T-400-10	DN	.455
H43505	5/16	N/R	05 'E'	T-400-32C	Black	T-400-10	DN	.555
H43506	3/8	N/R	06 'E'	T-400-33C	Black	T-400-10	DN	.615
H43508	1/2	N/R	08 'E'	T-400-34C	Black	T-400-10	DN	.765
H43512	3/4	N/R	12 'E'	T-400-35C	Black	T-400-10	DN	1.035
H43516	1	N/R	16 'E'	T-400-36C	Black	T-400-10	DN	1.295
H43604	1/4	N/R	04 'E'	T-400-31C	Black	T-400-10	DN	.455
H43605	5/16	N/R	05 'E'	T-400-32C	Black	T-400-10	DN	.555
H43606	3/8	N/R	06 'E'	T-400-33C	Black	T-400-10	DN	.615
H43608	1/2	N/R	08 'E'	T-400-34C	Black	T-400-10	DN	.765
H43612	3/4	N/R	12 'E'	T-400-35C	Black	T-400-10	DN	1.035
H43616	1	N/R	16 'E'	T-400-36C	Black	T-400-10	DN	1.295
H54504	1/4	N/R	04 'S'	T-400-2C	Yellow	T-400-62	DN	.560
	1/4	N/R	04 'U'	T-400-2C	Yellow	T-400-62	DN	.560

* Collet sits into two base halves, part number T-400BH and/or ET400AR-001.

Qualified on T-400 machine only.

Spacer Ring is Flat on both sides
Fits between two halves of T-400BH

BK=Black **BU**=Blue **OR**=Orange
RD=Red **TN**=Tan **WH**=White
YW=Yellow **SV**=Silver **MG**=Magenta
GY=Gray **GR**=Green **BR**=Brown

Tooling Selector Chart

T-400-1, T-400-17,
T-407-1, T-460,
T-462, T-465

HOSE TYPE	HOSE I.D. (IN.)	SKIVE TOOL	HOSE END PREFIX	COLLET PART #	SPACER RING COLOR	SPACER RING PART #	FLAT SIDE UP/DN	NOMINAL CRIMP DIA. (IN.)
	1/4	N/R	04 'W'	T-400-40C	Black	T-400-10	DN	.664
H54506	3/8	N/R	06 'S'	T-400-3C	Green	T-400-37	UP	.695
	3/8	N/R	06 'U'	T-400-3C	Green	T-400-37	UP	.695
	3/8	N/R	06 'W'	T-400-41C	Black	T-400-10	DN	.820
H54508	1/2	N/R	08 'M'	T-400-111C	Yellow	T-400-62	UP	.940
	1/2	N/R	08 'S'	T-400-4C	Black	T-400-10	DN	.865
	1/2	N/R	08 'U'	T-400-4C	Yellow	T-400-62	DN	.865
	1/2	N/R	08 'W'	T-400-42C	BK/TN	T-400-46R	UP	.992
H54510	5/8	N/R	10 'U'	T-400-64C	Yellow	T-400-62	UP	1.010
	5/8	N/R	10 'W'	T-400-43C*	N/R	N/R	N/R	1.132
H54512	3/4	N/R	12 'S'	T-400-5C	Yellow	T-400-62	DN	1.155
	3/4	N/R	12 'U'	T-400-5C	Yellow	T-400-62	DN	1.155
	3/4	N/R	12 'W'	T-400-44C*	BK/OR#	T-400-48R	N/A	1.293
H56904	3/16	N/R	06904 'E'	T-400-54C	Yellow	T-400-62	UP	.525
H56905	1/4	N/R	06905 'E'	T-400-55C	Black	T-400-10	UP	.585
H56906	5/16	N/R	06906 'E'	T-400-56C	Black	T-400-10	UP	.680
H56908	13/32	N/R	06908 'E'	T-400-57C	Yellow	T-400-62	UP	.765
H56910	1/2	N/R	06910 'E'	T-400-58C	Black	T-400-10	UP	.910
H56912	5/8	N/R	06912 'E'	T-400-59C	Silver	T-400-11	UP	1.080
H56916	7/8	N/R	06916 'E'	T-400-60C	Black	T-400-10	UP	1.275
H56920	1-1/8	N/R	06920 'E'	T-400-61C	Black	T-400-10	DN	1.485
H75706	5/16	N/R	75706 'E'	T-400-105C	Black	T-400-10	DN	.495
H75708	13/32	N/R	75708 'E'	T-400-106C	Black	T-400-10	DN	.595
H75710	1/2	N/R	75710 'E'	T-400-107C	Black	T-400-10	DN	.695
H75712	5/8	N/R	75712 'E'	T-400-108C	Black	T-400-10	DN	.850
H9610-6	3/8	N/R	06 'Z'	ET400DC-M195S	Purple	ET1000SR-M100A	UP	0.785
H9610-8	1/2	N/R	08 'Z'	ET400DC-M230S	Black	T-400-10	DN	0.940

Note:

T-420-25 adapter die ring required when using T-400 series collets.

BK=Black **BU**=Blue **OR**=Orange
RD=Red **TN**=Tan **WH**=White
YW=Yellow **SV**=Silver **MG**=Magenta
GY=Gray **GR**=Green **BR**=Brown

Tooling Selector Chart

T-420

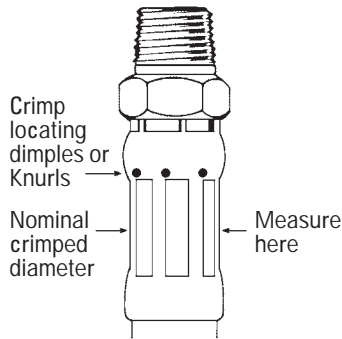
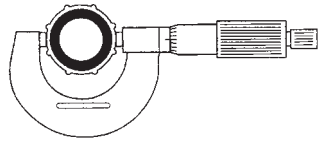

Note:
In larger sizes, calipers may be used; however, in smaller sizes, and in the 'E' Series thermoplastic hose ends, a point micrometer will provide an accurate reading. Nominal crimp diameters are for Weatherhead hose and end fittings when crimped with Weatherhead Coll-O-Crimp tooling.

Note:
T-420-25 adapter die ring required when using T-400 series collets.

⚠ WARNING

Proper Selection of Hose Ends: Selection of the proper end fittings for the hose end application is essential to the proper operation and safe use of the hose and related equipment. Inadequate attention to the selection of the end fittings for your application can result in leaking or the hose ends blowing off the hose, leading to serious bodily injury or property damage. In order to avoid serious bodily injury or property damage resulting from selection of the wrong end fitting, you should carefully review the information in the Weatherhead Catalog W-HYOV-MC002-E.

⚠ WARNING

Coll-O-Crimp Hose, Hose Fittings and Assembly Equipment Compatibility: The Coll-O-Crimp Equipment

Package, Coll-O-Crimp End Fittings, and Coll-O-Crimp Hose have been engineered and designed as a complete hose assembly system. Each component of the Coll-O-Crimp hose assembly system is compatible with other Coll-O-Crimp components to which it relates. Component compatibility, along with the use of quality components, insures the production of reliable hose assemblies when assembled properly. The use or intermixing of fittings and hose not specifically engineered and designed for use with each other and Coll-O-Crimp equipment is not recommended and may result in the production of unsafe or unreliable hose assemblies. This can result in hose assembly leakage, hose separation or other failures which can cause serious bodily injury or property damage from spraying

fluids, flying projectiles, or other substances. Eaton's Weatherhead warranty is limited to apply only when Coll-O-Crimp end fittings and compatible Coll-O-Crimp hose are used with Coll-O-Crimp assembly equipment. **Nominal Crimp Diameter Measurement:** Please remove this chart and place near your Coll-O-Crimp equipment for reference. Measuring crimp diameters should be a part of the normal hose assembly procedure. To insure a proper crimp diameter reading, follow these steps.

1. Measure the diameter in the middle of crimped portion of the hose end.
2. Place the caliper in a position to allow a measurement across the pressed (flat) portion of the crimp.
3. See crimp diameters on following chart.

T-420

HOSE TYPE	HOSE I.D. (IN.)	SKIVE TOOL	HOSE END PREFIX	COLLET PART #	SPACER RING COLOR	SPACER RING PART #	FLAT SIDE UP/DN	NOMINAL CRIMP DIA. (IN.)
H00905	5/16	N/R	05 'E'	T-400-32C	Black	T-400-10	UP	.585
H00906	3/8	N/R	06 'E'	T-400-33C	Black	T-400-10	UP	.655
H00908	1/2	N/R	08 'E'	T-400-34C	Black	T-400-10	UP	.805
H01704	1/4	N/R	04 'U'	T-400-2C	Yellow	T-400-62	UP	.580
H01706	3/8	N/R	06 'U'	T-400-3C	Black	T-400-10	UP	.785
H01708	1/2	N/R	08 'U'	T-400-4C	Silver	T-400-11	UP	.940
H01712	3/4	N/R	12 'U'	T-400-5C	Silver	T-400-11	UP	1.235
H01716	1	N/R	16 'U'	T-400-6C	Silver	T-400-11	UP	1.525
H01720	1-1/4	N/R	20 'U'	T-400-12	Black	T-400-10	DN	1.785
H03912	3/4	N/R	12 'S'	T-400-5C	Silver	T-400-11	UP	1.230
	3/4	N/R	12 'U'	T-400-5C	Silver	T-400-11	UP	1.230
	3/4	N/R	12 'Z'	T-420-5CN	Tan	T-400-112	UP	1.401
H039H12	3/4	N/R	12 'Z'	T-420-5CN	Tan	T-400-112	UP	1.401
H03916	1	N/R	16 'S'	T-400-6C	Silver	T-400-11	UP	1.520
	1	N/R	16 'U'	T-400-6C	Silver	T-400-11	UP	1.520
	1	N/R	16 'Z'	T-400-6CN	N/R	N/R	N/R	1.708
H039H16	1	N/R	16 'Z'	T-400-6CN	N/R	N/R	N/R	1.708
H03920	1-1/4	N/R	20 'S'	T-400-12	Black	T-400-10	DN	1.790
	1-1/4	N/R	20 'U'	T-400-12	Black	T-400-10	DN	1.790
	1-1/4	N/R	20 'Z'	T-420-7CN	N/R	N/R	N/R	2.206
H039H20	1-1/4	N/R	20 'Z'	T-420-7CN	N/R	N/R	N/R	2.206
H05904	3/16	N/R	06904 'E'	T-400-54C	Yellow	T-400-62	UP	.525
	3/16	N/R	22904 'P'	T-400-80C	Black	T-400-10	DN	.480
H05905	1/4	N/R	06905 'E'	T-400-55C	Black	T-400-10	UP	.585

Note:
T-420-25 adapter die ring required when using T-400 series collets.

BK=Black **BU**=Blue **OR**=Orange
RD=Red **TN**=Tan **WH**=White
YW=Yellow **SV**=Silver **MG**=Magenta
GY=Gray **GR**=Green **BR**=Brown

Tooling Selector Chart

T-420

HOSE TYPE	HOSE I.D. (IN.)	SKIVE TOOL	HOSE END PREFIX	COLLET PART #	SPACER RING COLOR	SPACER RING PART #	FLAT SIDE UP/DN	NOMINAL CRIMP DIA. (IN.)
H05906	5/16	N/R	06906 'E'	T-400-56C	Black	T-400-10	UP	.680
H05906	5/16	N/R	22906 'P'	T-400-81C	Black	T-400-10	DN	.650
H05908	13/32	N/R	06908 'E'	T-400-57C	Yellow	T-400-62	UP	.765
	13/32	N/R	22908 'P'	T-400-82C	Black	T-400-10	DN	.775
H05910	1/2	N/R	06910 'E'	T-400-58C	Black	T-400-10	UP	.910
	1/2	N/R	22910 'P'	T-400-83C	Black	T-400-10	DN	.875
H05912	5/8	N/R	06912 'E'	T-400-59C	Silver	T-400-11	UP	1.080
H05916	7/8	N/R	06916 'E'	T-400-60C	Black	T-400-10	UP	1.275
H06904	3/16	N/R	06904 'E'	T-400-54C	Yellow	T-400-62	UP	.525
H06905	1/4	N/R	06905 'E'	T-400-55C	Black	T-400-10	UP	.585
H06906	5/16	N/R	06906 'E'	T-400-56C	Black	T-400-10	UP	.680
H06908	13/32	N/R	06908 'E'	T-400-57C	Yellow	T-400-62	UP	.765
H06910	1/2	N/R	06910 'E'	T-400-58C	Black	T-400-10	UP	.910
H06912	5/8	N/R	06912 'E'	T-400-59C	Silver	T-400-11	UP	1.080
H06916	7/8	N/R	06916 'E'	T-400-60C	Black	T-400-10	UP	1.275
H06920	1-1/8	N/R	06920 'E'	T-400-61C	Yellow	T-400-62	UP	1.520
H06924	1-3/8	N/R	06924 'E'	T-400-70	Black	T-400-10	UP	1.730
H10404	1/4	N/R	04 'S'	T-400-2C	Black	T-400-10	DN	.561
	1/4	N/R	04 'U'	T-400-2C	Black	T-400-10	DN	.560
	1/4	N/R	04 'W'	T-400-40C	Black	T-400-10	DN	.664
	1/4	N/R	04 'Z'	ET400DC-M150S	Purple	ET1000SR-M100A	UP	0.620
H10406	3/8	N/R	06 'S'	T-400-3C	Black	T-400-10	DN	.740
	3/8	N/R	06 'U'	T-400-3C	Black	T-400-10	DN	.740
	3/8	N/R	06 'W'	T-400-41C	Black	T-400-10	DN	.820
	3/8	N/R	06 'Z'	ET400DC-M195S	Purple	ET1000SR-M100A	UP	0.785
H10408	1/2	N/R	08 'S'	T-400-4C	Black	T-400-10	DN	.863
	1/2	N/R	08 'U'	T-400-4C	Black	T-400-10	DN	.870
	1/2	N/R	08 'W'	T-400-42C	Black	T-400-10	DN	.976
	1/2	N/R	08 'Z'	ET400DC-M230S	Black	T-400-10	DN	0.940
H10410	5/8	N/R	10 'U'	T-400-64C	Black	T-400-10	DN	1.000
	5/8	N/R	10 'W'	T-420-85C	BK/WH	T-420-80R	UP	1.132
	5/8	N/R	10 'Z'	T-420-85C	Pink	ET420SR-M660A	UP	1.055
H10412	3/4	N/R	12 'S'	T-400-5C	Yellow	T-400-62	UP	1.177
	3/4	N/R	12 'U'	T-400-5C	Black	T-400-10	DN	1.160
	3/4	N/R	12 'W'	T-420-86C	BK/BU	T-420-82R	UP	1.260
	3/4	N/R	12 'Z'	T-420-86C	Brown	ET420SR-M495A	UP	1.250
H10416	1	N/R	16 'S'	T-400-6C	Yellow	T-400-62	UP	1.465
	1	N/R	16 'U'	T-400-6C	Black	T-400-10	DN	1.450
	1	N/R	16 'W'	T-420-87C	BK/WH	T-420-80R	UP	1.587
	1	N/R	16 'Z'	ET420DC-M380S	Orange	T-420-29	UP	1.590
H10420	1-1/4	N/R	20 'S'	T-400-12	Black	T-400-10	DN	1.790
	1-1/4	N/R	20 'U'	T-400-12	Black	T-400-10	DN	1.785
H10504	1/4	N/R	04 'U'	T-400-2C	Black	T-400-10	UP	.610
H10506	3/8	N/R	06 'U'	T-400-3C	Black	T-400-10	UP	.788
H10508	1/2	N/R	08 'U'	T-400-4C	Silver	T-400-11	UP	.940
H10512	3/4	N/R	12 'U'	T-400-5C	Silver	T-400-11	UP	1.232
H10516	1	N/R	16 'U'	T-400-6C	Silver	T-400-11	DN	1.435
H11404	1/4	N/R	04 'S'	T-400-2C	Green	T-400-37	UP	.520
	1/4	N/R	04 'U'	T-400-2C	Green	T-400-37	UP	.520
H11406	3/8	N/R	06 'S'	T-400-3C	Green	T-400-37	UP	.695
	3/8	N/R	06 'U'	T-400-3C	Green	T-400-37	UP	.695
H11408	1/2	N/R	08 'S'	T-400-4C	Black	T-400-10	DN	.860
	1/2	N/R	08 'U'	T-400-4C	Green	T-400-37	UP	.830
H11504	1/4	N/R	04 'U'	T-400-2C	Black	T-400-10	UP	.610
H11506	3/8	N/R	06 'U'	T-400-3C	Black	T-400-10	UP	.788
H11508	1/2	N/R	08 'U'	T-400-4C	Silver	T-400-11	UP	.940
H11512	3/4	N/R	12 'U'	T-400-5C	Silver	T-400-11	UP	1.232
H11516	1	N/R	16 'U'	T-400-6C	Silver	T-400-11	UP	1.522
H11520	1-1/4	N/R	20 'U'	T-400-12	Silver	T-400-11	UP	1.862

Note:
T-420-25 adapter die ring required when using T-400 series collets.

BK=Black **BU**=Blue **OR**=Orange
RD=Red **TN**=Tan **WH**=White
YW=Yellow **SV**=Silver **MG**=Magenta
GY=Gray **GR**=Green **BR**=Brown

Tooling Selector Chart

T-420

HOSE TYPE	HOSE I.D. (IN.)	SKIVE TOOL	HOSE END PREFIX	COLLET PART #	SPACER RING COLOR	SPACER RING PART #	FLAT SIDE UP/DN	NOMINAL CRIMP DIA. (IN.)
H14504	1/4	N/R	04 'M'	T-400-109C	Yellow	T-400-62	UP	.630
	1/4	N/R	04 'S'	T-400-2C	Green	T-400-37	UP	.520
	1/4	N/R	04 'U'	T-400-2C	Green	T-400-37	Up	.520
	1/4	N/R	04 'W'	T-400-40C	BK/TN	T-400-46R	UP	.678
	1/4	N/R	04 'Z'	ET400DC-M150S	Purple	ET1000SR-M100A	UP	.612
H145R04	1/4	N/R	04 'Z'	ET400DC-M150S	Purple	ET1000SR-M100A	UP	.612
H14506	3/8	N/R	06 'M'	T-400-110C	Yellow	T-400-62	UP	.765
	3/8	N/R	06 'S'	T-400-3C	Green	T-400-37	UP	.695
	3/8	N/R	06 'U'	T-400-3C	Green	T-400-37	UP	.695
	3/8	N/R	06 'W'	T-400-41C	Green	T-400-37	UP	.782
	3/8	N/R	06 'Z'	ET400DC-M195S	Green	T-400-37	UP	.775
H145R06	3/8	N/R	06 'Z'	ET400DC-M195S	Green	T-400-37	UP	.775
H14508	1/2	N/R	08 'M'	T-400-111C	Yellow	T-400-62	UP	.935
	1/2	N/R	08 'S'	T-400-4C	Yellow	T-400-62	DN	.870
	1/2	N/R	08 'U'	T-400-4C	Yellow	T-400-62	DN	.870
	1/2	N/R	08 'W'	T-400-42C	Black	T-400-10	DN	.976
	1/2	N/R	08 'Z'	ET400DC-M230S	Purple	ET1000SR-M100A	UP	.920
H145R08	1/2	N/R	08 'Z'	ET400DC-M230S	Purple	ET1000SR-M100A	UP	.920
H14510	5/8	N/R	10 'M'	T-420 30C	Orange	T-420-29	UP	1.085
	5/8	N/R	10 'U'	T-400-64C	Yellow	T-400-62	UP	1.010
	5/8	N/R	10 'W'	T-420-85C	N/R	N/R	N/R	1.149
	5/8	N/R	10 'Z'	T-420-85C	BK/GY	ET420SR-M255A	UP	1.115
H145R10	5/8	N/R	10 'Z'	T-420-85C	BK/GY	ET420SR-M255A	UP	1.115
H14512	3/4	N/R	12 'S'	T-400-5C	Yellow	T-400-62	DN	1.160
	3/4	N/R	12 'U'	T-400-5C	Yellow	T-400-62	DN	1.160
	3/4	N/R	12 'W'	T-420-86C	BK/OR	T-420-81R	UP	1.293
	3/4	N/R	12 'Z'	T-420-86C	Orange	T-420-29	UP	1.275
H145R12	3/4	N/R	12 'Z'	T-420-86C	Orange	T-420-29	UP	1.275
H14516	1	N/R	16 'S'	T-400-6C	Yellow	T-400-62	DN	1.445
	1	N/R	43016 'U'	T-420-6CN	Orange	T-420-29	UP	1.655
	1	N/R	16 'W'	T-420-87C	BK/WH	T-420-80R	UP	1.587
	1	N/R	16 'Z'	ET420DC-M380S	BK/BU	T-420-82R	UP	1.575
H145R16	1	N/R	16 'Z'	ET420DC-M380S	BK/BU	T-420-82R	UP	1.575
H14604	1/4	N/R	04 'U'	T-400-2C	Green	T-400-37	UP	.520
H14606	3/8	N/R	06 'U'	T-400-3C	Green	T-400-37	UP	.695
H14608	1/2	N/R	08 'U'	T-400-4C	Green	T-400-37	UP	.830
H16604	3/16	N/R	06904 'E'	T-400-54C	Yellow	T-400-62	UP	.525
H16605	1/4	N/R	06905 'E'	T-400-55C	Black	T-400-10	UP	.585
H16606	5/16	N/R	06906 'E'	T-400-56C	Black	T-400-10	UP	.680
H16608	13/32	N/R	06908 'E'	T-400-57C	Yellow	T-400-62	UP	.765
H16610	1/2	N/R	06910 'E'	T-400-58C	Black	T-400-10	UP	.910
H16612	5/8	N/R	06912 'E'	T-400-59C	Silver	T-400-11	UP	1.080
H16616	7/8	N/R	06916 'E'	T-400-60C	Black	T-400-10	UP	1.275
H16620	1-1/8	N/R	06920 'E'	T-400-61C	Yellow	T-400-62	UP	1.520
H16904	3/16	N/R	06904 'E'	T-400-54C	Yellow	T-400-62	UP	.525
H16905	1/4	N/R	06905 'E'	T-400-55C	Black	T-400-10	UP	.585
H16906	5/16	N/R	06906 'E'	T-400-56C	Black	T-400-10	UP	.680
H16908	13/32	N/R	06908 'E'	T-400-57C	Yellow	T-400-62	UP	.765
H16910	1/2	N/R	06910 'E'	T-400-58C	Black	T-400-10	UP	.910
H16912	5/8	N/R	06912 'E'	T-400-59C	Silver	T-400-11	UP	1.080
H16916	7/8	N/R	06916 'E'	T-400-60C	Black	T-400-10	UP	1.275
H16920	1-1/8	N/R	06920 'E'	T-400-61C	Yellow	T-400-62	UP	1.520
H16924	1-3/8	N/R	06924 'E'	T-400-70	Black	T-400-10	UP	1.730
H19004	1/4	N/R	04 'W'	T-400-40C	Black	T-400-10	DN	.664
	1/4	N/R	04 'Z'	ET400DC-M150S	Purple	ET1000SR-M100A	UP	.620
H190H04	1/4	N/R	04 'Z'	ET400DC-M150S	Purple	ET1000SR-M100A	UP	.620
H19006	3/8	N/R	06 'W'	T-400-41C	Black	T-400-10	DN	.820
	3/8	N/R	06 'Z'	ET400DC-M195S	Purple	T-400-37	UP	.770
H190H06	3/8	N/R	06 'Z'	ET400DC-M195S	Green	T-400-37	UP	.770

Note:

T-420-25 adapter die ring required when using T-400 series collets.

BK=Black **BU**=Blue **OR**=Orange
RD=Red **TN**=Tan **WH**=White
YW=Yellow **SV**=Silver **MG**=Magenta
GY=Gray **GR**=Green **BR**=Brown

Tooling Selector Chart

T-420

HOSE TYPE	HOSE I.D. (IN.)	SKIVE TOOL	HOSE END PREFIX	COLLET PART #	SPACER RING COLOR	SPACER RING PART #	FLAT SIDE UP/DN	NOMINAL CRIMP DIA. (IN.)
H19008	1/2	N/R	08 'W'	T-400-42C	Black	T-400-10	DN	.976
	1/2	N/R	08 'Z'	ET400DC-M230S	Black	T-400-10	DN	0.940
H190H08	1/2	N/R	08 'Z'	ET400DC-M230S	Black	T-400-10	DN	0.940
H19010	5/8	N/R	10 'W'	T-420-85C	BK/WH	T-420-80R	UP	1.132
	5/8	N/R	10 'Z'	T-420-85C	Pink	ET420SR-M660A	UP	1.055
H190H10	5/8	N/R	10 'Z'	T-420-85C	Pink	ET420SR-M660A	UP	1.055
H19012	3/4	N/R	12 'W'	T-420-86C	BK/BU	T-420-82R	UP	1.260
	3/4	N/R	12 'Z'	T-420-86C	Brown	ET420SR-M495A	UP	1.250
H190H12	3/4	N/R	12 'Z'	T-420-86C	Brown	ET420SR-M495A	UP	1.250
H19016	1	N/R	16 'W'	T-420-87C	BK/WH	T-420-80R	UP	1.587
	1	N/R	16 'Z'	ET420DC-M380S	Orange	T-420-29	UP	1.590
H190H16	1	N/R	16 'Z'	ET420DC-M380S	Orange	T-420-29	UP	1.590
H19020	1-1/4	N/R	20 'Z'	ET420DC-M420S	N/R	N/R	UP	1.800
H190H20	1-1/4	N/R	20 'Z'	ET420DC-M420S	N/R	N/R	UP	1.800
H20904	1/4	N/R	04 'E'	T-400-31C	Black	T-400-10	DN	.455
H20905	5/16	N/R	05 'E'	T-400-32C	Black	T-400-10	DN	.555
H20906	3/8	N/R	06 'E'	T-400-33C	Black	T-400-10	DN	.615
H20908	1/2	N/R	08 'E'	T-400-34C	Black	T-400-10	DN	.765
H22904	3/16	N/R	06904 'E'	T-400-54C	Yellow	T-400-62	UP	.525
	3/16	N/R	22904 'P'	T-400-80C	Yellow	T-400-62	UP	.505
H22906	5/16	N/R	06906 'E'	T-400-56C	Black	T-400-10	UP	.680
	5/16	N/R	22906 'P'	T-400-81C	Black	T-400-10	DN	.650
H22908	13/32	N/R	06908 'E'	T-400-57C	Yellow	T-400-62	UP	.765
	13/32	N/R	22908 'P'	T-400-82C	Black	T-400-10	DN	.775
H22910	1/2	N/R	06910 'E'	T-400-58C	Black	T-400-10	UP	.910
	1/2	N/R	22910 'P'	T-400-83C	Black	T-400-10	DN	.875
H22912	5/8	N/R	06912 'E'	T-400-59C	Silver	T-400-11	UP	1.080
H22916	7/8	N/R	06916 'E'	T-400-60C	Black	T-400-10	UP	1.275
H23904	3/16	N/R	069 'E'	T-400-54C	Yellow	T-400-62	UP	.525
	3/16	N/R	229 'P'	T-400-80C	Black	T-400-10	DN	.480
H23906	5/16	N/R	069 'E'	T-400-56C	Black	T-400-10	UP	.680
	5/16	N/R	229 'P'	T-400-81C	Black	T-400-10	DN	.650
H23908	13/32	N/R	069 'E'	T-400-57C	Yellow	T-400-62	UP	.765
	13/32	N/R	229 'P'	T-400-82C	Black	T-400-10	DN	.775
H23910	1/2	N/R	069 'E'	T-400-58C	Black	T-400-10	UP	.910
	1/2	N/R	229 'P'	T-400-83C	Black	T-400-10	DN	.875
H23912	5/8	N/R	069 'E'	T-400-59C	Silver	T-400-11	UP	1.080
H23916	7/8	N/R	069 'E'	T-400-60C	Black	T-400-10	UP	1.275
H23920	1-1/8	N/R	069 'E'	T-400-61C	Yellow	T-400-62	UP	1.510
H24303	3/16	N/R	03 'E'	T-400-113C	Tan	T-400-112	UP	.355
H24304	1/4	N/R	04 'E'	T-400-31C	Green	T-400-37	UP	.405
H24305	5/16	N/R	05 'E'	T-400-32C	Red	T-400-38	UP	.475
H24306	3/8	N/R	06 'E'	T-400-33C	Red	T-400-38	UP	.545
H24308	1/2	N/R	08 'E'	T-400-34C	Red	T-400-38	UP	.695
H24312	3/4	N/R	12 'E'	T-400-35C	Red	T-400-38	UP	.978
H24316	1	N/R	16 'E'	T-400-36C	Red	T-400-38	UP	1.225
H24504	1/4	N/R	04 'M'	T-400-109C	Black	T-400-10	UP	.665
	1/4	N/R	04 'S'	T-400-2C	Yellow	T-400-62	DN	.560
	1/4	N/R	04 'U'	T-400-2C	Yellow	T-400-62	DN	.560
	1/4	N/R	04 'W'	T-400-40C	BK/TN	T-400-46R	UP	.678
	1/4	N/R	04 'Z'	ET400DC-M150S	Black	T-400-10	DN	.640
H245L04	1/4	N/R	04 'Z'	ET400DC-M150S	Black	T-400-10	DN	.640
H24506	3/8	N/R	06 'M'	T-400-110C	Black	T-400-10	UP	.805
	3/8	N/R	06 'S'	T-400-3C	Yellow	T-400-62	DN	.740
	3/8	N/R	06 'U'	T-400-3C	Yellow	T-400-62	DN	.740
	3/8	N/R	06 'W'	T-400-41C	Black	T-400-10	DN	.820
	3/8	N/R	06 'Z'	ET400DC-M195S	Tan	T-400-112	UP	.800
H245L06	3/8	N/R	06 'Z'	ET400DC-M195S	Tan	T-400-112	UP	.800
H24508	1/2	N/R	08 'M'	T-400-111C	Yellow	T-400-62	UP	.940

Note:
T-420-25 adapter die ring required when using T-400 series collets.

BK=Black **BU**=Blue **OR**=Orange
RD=Red **TN**=Tan **WH**=White
YW=Yellow **SV**=Silver **MG**=Magenta
GY=Gray **GR**=Green **BR**=Brown

Tooling Selector Chart

T-420

HOSE TYPE	HOSE I.D. (IN.)	SKIVE TOOL	HOSE END PREFIX	COLLET PART #	SPACER RING COLOR	SPACER RING PART #	FLAT SIDE UP/DN	NOMINAL CRIMP DIA. (IN.)
	1/2	N/R	08 'S'	T-400-4C	Yellow	T-400-62	DN	.865
	1/2	N/R	08 'U'	T-400-4C	Yellow	T-400-62	DN	.865
	1/2	N/R	08 'W'	T-400-42C	BK/TN	T-400-46R	UP	.993
	1/2	N/R	08 'Z'	ET400DC-M230S	Lt. Green	ET1000SR-M190D	UP	.975
H245L08	1/2	N/R	08 'Z'	ET400DC-M230S	Lt. Green	ET1000SR-M190D	UP	.975
H24510	5/8	N/R	10 'M'	T-420-30C	Orange	T-420-29	UP	1.085
	5/8	N/R	10 'U'	T-400-64C	Yellow	T-400-62	UP	1.010
	5/8	N/R	10 'W'	T-420-85C	BK/WH	T-420-80R	UP	1.132
	5/8	N/R	10 'Z'	T-420-85C	BK/GY	ET420SR-M255A	UP	1.115
H245L10	5/8	N/R	10 'Z'	T-420-85C	BK/GY	ET420SR-M255A	UP	1.115
H24512	3/4	N/R	12 'S'	T-400-5C	Yellow	T-400-62	DN	1.160
	3/4	N/R	12 'U'	T-400-5C	Yellow	T-400-62	DN	1.160
H24512	3/4	N/R	43012 'U'	T-420-5CN	Orange	T-420-29	UP	1.365
	3/4	N/R	12 'W'	T-420-86C	BK/OR	T-420-81R	UP	1.293
	3/4	N/R	12 'Z'	T-420-86C	Brown	ET420SR-M495A	UP	1.245
H245L12	3/4	N/R	12 'Z'	T-420-86C	Brown	ET420SR-M495A	UP	1.245
H24516	1	N/R	16 'S'	T-400-6C	Yellow	T-400-62	UP	1.465
	1	N/R	16 'U'	T-400-6C	Yellow	T-400-62	UP	1.465
	1	N/R	43016 'U'	T-420-6CN	Orange	T-420-29	UP	1.660
	1	N/R	16 'W'	T-420-87C	BK/WH	T-420-80R	UP	1.587
	1	N/R	16 'Z'	ET420DC-M380S	Brown	ET420SR-M495A	UP	1.565
H245L16	1	N/R	16 'Z'	ET420DC-M380S	Brown	ET420SR-M495A	UP	1.565
H24520	1-1/4	N/R	20 'S'	T-400-12	Yellow	T-400-62	DN	1.795
	1-1/4	N/R	20 'U'	T-400-12	Yellow	T-400-62	DN	1.795
	1-1/4	N/R	20 'Z'	ET420DC-M480S	BK/BU	T-400-62	DN	1.795
	1-1/4	N/R	43020 'U'	T-420-7CN	Orange	T-420-29	UP	1.990
H245L20	1-1/4	N/R	20 'Z'	ET420DC-M480S	BK/BU	T-420-82R	UP	1.900
H26504	1/4	N/R	26504 'P'	T-400-2C	Green	T-400-37	UP	.520
H26506	3/8	N/R	06 'E'	T-400-33C	Black	T-400-10	UP	.660
	3/8	N/R	26506 'P'	T-400-2C	Silver	T-400-11	UP	.640
H26508	1/2	N/R	08 'E'	T-400-34C	Black	T-400-10	UP	.810
H26508	1/2	N/R	26508 'P'	T-400-3C	Black	T-400-10	UP	.778
H26512	3/4	N/R	12 'E'	T-400-35C	Black	T-400-10	UP	1.090
	3/4	N/R	26512 'P'	T-400-64C	Silver	T-400-11	UP	1.070
H26516	1	N/R	16 'E'	T-400-36C	Black	T-400-10	UP	1.340
H27504	1/4	N/R	26504 'P'	T-400-2C	Green	T-400-37	UP	.520
H27506	3/8	N/R	06 'E'	T-400-33C	Black	T-400-10	UP	.660
	3/8	N/R	26506 'P'	T-400-2C	Silver	T-400-11	UP	.640
H27508	1/2	N/R	08 'E'	T-400-34C	Black	T-400-10	UP	.810
	1/2	N/R	26508 'P'	T-400-3C	Black	T-400-10	UP	.788
H27512	3/4	N/R	12 'E'	T-400-35C	Black	T-400-10	UP	1.090
	3/4	N/R	26512 'P'	T-400-64C	Silver	T-400-11	UP	1.070
H27516	1	N/R	16 'E'	T-400-36C	Black	T-400-10	UP	1.340
H27703	3/16	N/R	03 'E'	T-400-113C	Tan	T-400-112	UP	.355
H27704	1/4	N/R	04 'E'	T-400-31C	Green	T-400-37	UP	.405
H27705	5/16	N/R	05 'E'	T-400-32C	Red	T-400-38	UP	.475
H27706	3/8	N/R	06 'E'	T-400-33C	Red	T-400-38	UP	.545
H27708	1/2	N/R	08 'E'	T-400-34C	Red	T-400-38	UP	.695
H27712	3/4	N/R	12 'E'	T-400-35C	Red	T-400-38	UP	.978
H27716	1	N/R	16 'E'	T-400-36C	Red	T-400-38	UP	1.225
H28004	1/4	N/R	04 'W'	T-400-40C	BK/TN	T-400-46R	UP	.678
	1/4	N/R	04 'Z'	ET400DC-M150S	Yellow	T-400-62	UP	.665
H28006	3/8	N/R	06 'W'	T-400-41C	Black	T-400-10	DN	.820
	3/8	N/R	06 'Z'	ET400DC-M195S	Black	T-400-10	DN	.815
H28008	1/2	N/R	08 'W'	T-400-42C	BK/TN	T-400-46R	UP	.992
	1/2	N/R	08 'Z'	ET400DC-M230S	Lt. Green	ET1000SR-M190D	UP	.975
H28010	5/8	N/R	10 'W'	T-420-85C	BK/WH	T-420-80R	UP	1.132
	5/8	N/R	10 'Z'	T-420-85C	BK/GY	ET420SR-M255A	UP	1.115
H28012	3/4	N/R	12 'W'	T-420-86C	BK/OR	T-420-81R	UP	1.293

Note:

T-420-25 adapter die ring required when using T-400 series collets.

BK=Black **BU**=Blue **OR**=Orange
RD=Red **TN**=Tan **WH**=White
YW=Yellow **SV**=Silver **MG**=Magenta
GY=Gray **GR**=Green **BR**=Brown

Tooling Selector Chart

T-420

HOSE TYPE	HOSE I.D. (IN.)	SKIVE TOOL	HOSE END PREFIX	COLLET PART #	SPACER RING COLOR	SPACER RING PART #	FLAT SIDE UP/DN	NOMINAL CRIMP DIA. (IN.)
	3/4	N/R	12 'Z'	T-420-86C	Brown	ET420SR-M495A	UP	1.245
H28016	1	N/R	16 'W'	T-420-87C	BK/WH	T-420-80R	UP	1.587
	1	N/R	16 'Z'	ET420DC-M380S	Brown	ET420SR-M495A	UP	1.565
H28504	1/4	N/R	04 'E'	T-400-31C	Black	T-400-10	UP	.500
	1/4	N/R	26504 'P'	T-400-2C	Green	T-400-37	UP	.520
H28506	3/8	N/R	06 'E'	T-400-33C	Black	T-400-10	UP	.660
	3/8	N/R	26506 'P'	T-400-2C	Silver	T-400-11	UP	.640
H28508	1/2	N/R	08 'E'	T-400-34C	Black	T-400-10	UP	.810
	1/2	N/R	26508 'P'	T-400-3C	Black	T-400-10	UP	.788
H28512	3/4	N/R	12 'E'	T-400-35C	Black	T-400-10	UP	1.090
	3/4	N/R	26512 'P'	T-400-64C	Silver	T-400-11	UP	1.070
H28516	1	N/R	16 'E'	T-400-36C	Black	T-400-10	UP	1.340
H29004	1/4	N/R	04 'W'	T-400-40C	Black	T-400-10	UP	.722
	1/4	N/R	04 'Z'	ET400DC-M150S	Lt. Green	ET1000SR-M190D	UP	.680
H290H04	1/4	N/R	04 'Z'	ET400DC-M150S	Lt. Green	ET1000SR-M190D	UP	.680
H29006	3/8	N/R	06 'W'	T-400-41C	BK/RD	T-400-47R	UP	.854
	3/8	N/R	06 'Z'	ET400DC-M195S	Yellow	T-400-62	UP	.835
H290H06	3/8	N/R	06 'Z'	ET400DC-M195S	Yellow	T-400-62	UP	.835
H29008	1/2	N/R	08 'W'	T-400-42C	BK/RD	T-400-47R	UP	1.007
	1/2	N/R	08 'Z'	ET400DC-M230S	Black	T-400-10	UP	.990
H290H08	1/2	N/R	08 'Z'	ET400DC-M230S	Black	T-400-10	UP	.990
H29010	5/8	N/R	10 'W'	T-420-85C	N/R	N/R	N/R	1.149
	5/8	N/R	10 'Z'	T-420-85C	BK/WH	T-420-80R	UP	1.130
H290H10	5/8	N/R	10 'Z'	T-420-85C	BK/WH	T-420-80R	UP	1.130
H29012	3/4	N/R	12 'W'	T-420-86C	N/R	N/R	N/R	1.317
	3/4	N/R	12 'Z'	T-420-86C	BK/GY	ET420SR-M255A	UP	1.280
H290H12	3/4	N/R	12 'Z'	T-420-86C	BK/GY	ET420SR-M255A	UP	1.280
H29016	1	N/R	16 'W'	T-420-87C	N/R	N/R	N/R	1.607
	1	N/R	16 'Z'	ET420DC-M380S	N/A	N/A	N/A	1.640
H290H16	1	N/R	16 'Z'	ET420DC-M380S	N/A	N/A	N/A	1.640
H29020	1-1/4	N/R	20 'Z'	T420-7CN	N/R	N/R	N/R	2.000
	1-1/4	N/R	20 'Z'	ET420DC-M480S	N/R	N/R	N/R	1.960
H290H20	1-1/4	N/R	20 'Z'	T420-7CN	N/R	N/R	N/R	2.000
H32406	3/8	N/R	06 'U'	T-400-3C	Black	T-400-10	UP	.785
H32504	1/4	N/R	04 'U'	T-400-2C	Black	T-400-10	UP	.610
H32506	3/8	N/R	06 'U'	T-400-3C	Black	T-400-10	UP	.795
H32508	1/2	N/R	08 'U'	T-400-4C	Yellow	T-400-62	UP	.885
H32512	3/4	N/R	12 'U'	T-400-5C	Black	T-400-10	UP	1.215
H32516	1	N/R	16 'U'	T-400-6C	Silver	T-400-11	UP	1.525
H33503	3/16	N/R	33603 'E'	T-400-120C	Black	T-400-10	UP	.540
H33504	1/4	N/R	33604 'E'	T-400-121C	Black	T-400-10	UP	.667
H33506	3/8	N/R	33606 'E'	T-400-122C	Black	T-400-10	UP	.770
H33508	1/2	N/R	33608 'E'	T-400-123C	Black	T-400-10	UP	.895
H33512	3/4	N/R	33612 'E'	T-420-15C	Black	T-400-10	UP	1.115
H33516	1	N/R	33616 'E'	T-420-16C	Black	T-400-10	UP	1.455
H33603	3/16	N/R	33603 'E'	T-400-120C	Black	T-400-10	UP	.540
H33604	1/4	N/R	33604 'E'	T-400-121C	Black	T-400-10	UP	.667
H33606	3/8	N/R	33606 'E'	T-400-122C	Black	T-400-10	UP	.770
H33608	1/2	N/R	33608 'E'	T-400-123C	Black	T-400-10	UP	.895
H33612	3/4	N/R	33612 'E'	T-420-15C	Black	T-400-10	UP	1.115
H33616	1	N/R	33616 'E'	T-420-16C	Black	T-400-10	UP	1.455
H33806	3/8	N/R	33806 'P'	T-400-102C	Black	T-400-10	DN	.700
H33808	1/2	N/R	33808 'P'	T-400-103C	Black	T-400-10	DN	.795
H34504	1/4	N/R	04 'M'	T-400-109C	Yellow	T-400-62	UP	.630
	1/4	N/R	04 'W'	T-400-40C	Black	T-400-10	DN	.664
	1/4	N/R	04 'Z'	ET400DC-M150S	Tan	T-400-112	UP	.625
H34506	3/8	N/R	06 'M'	T-400-110C	Yellow	T-400-62	UP	.765
	3/8	N/R	06 'W'	T-400-41C	Green	T-400-37	UP	.782

Note:
T-420-25 adapter die ring required when using T-400 series collets.

BK=Black **BU**=Blue **OR**=Orange
RD=Red **TN**=Tan **WH**=White
YW=Yellow **SV**=Silver **MG**=Magenta
GY=Gray **GR**=Green **BR**=Brown

Tooling Selector Chart

T-420

HOSE TYPE	HOSE I.D. (IN.)	SKIVE TOOL	HOSE END PREFIX	COLLET PART #	SPACER RING COLOR	SPACER RING PART #	FLAT SIDE UP/DN	NOMINAL CRIMP DIA. (IN.)
	3/8	N/R	06 'Z'	ET400DC-M195S	Green	T-400-37	UP	.775
H34508	1/2	N/R	08 'M'	T-400-111C	Yellow	T-400-62	DN	.915
	1/2	N/R	08 'W'	T-400-42C	Black	T-400-10	DN	.976
	1/2	N/R	08 'Z'	ET400DC-M230S	Black	T-400-10	DN	.940
H35006	3/8	N/R	06 'M'	T-400-110C	Black	T-400-10	UP	.805
	3/8	N/R	06 'W'	T-400-41C	Black	T-400-10	DN	.820
	3/8	N/R	06 'U'	T-400-3C	Yellow	T-400-62	DN	.740
	3/8	N/R	06 'Z'	ET400DC-M195S	Black	T-400-10	DN	.815
H35008	1/2	N/R	08 'M'	T-400-111C	Yellow	T-400-62	UP	.945
	1/2	N/R	08 'W'	T-400-42C	BK/TN	T-400-46R	UP	.993
	1/2	N/R	08 'U'	T-400-4C	Yellow	T-400-62	DN	.865
	1/2	N/R	08 'Z'	ET400DC-M230S	Lt. Green	ET1000SR-M190D	UP	.975
H35010	5/8	N/R	10 'M'	T-420-30C	N/R	N/R	N/R	1.120
	5/8	N/R	10 'W'	T-420-85C	BK/WH	T-420-80R	UP	1.132
	5/8	N/R	10 'Z'	T-420-85C	BK/WH	T-420-80R	UP	1.130
H35012	3/4	N/R	43012 'U'	T-420-5CN	N/R	N/R	N/R	1.413
H35016	1	N/R	43016 'U'	T-420-6CN	N/R	N/R	N/R	1.705
H36606	5/16	N/R	06906 'E'	T-400-56C	Black	T-400-10	UP	.680
H36608	13/32	N/R	06908 'E'	T-400-57C	Yellow	T-400-62	UP	.765
H40006	1/4	N/R	04 'Z'	ET400DC-M195S	Yellow	T-400-62	UP	.835
H40008	3/8	N/R	06 'Z'	ET400DC-M230S	Black	T-400-10	UP	.990
H40010	5/8	N/R	10 'M'	T-420-30C	N/R	N/R	N/R	1.120
	5/8	N/R	10 'W'	T-420-85C	N/R	N/R	N/R	1.149
	5/8	N/R	10 'Z'	T-420-85C	BK/WH	T-420-80R	UP	1.129
H40012	3/4	N/R	12 'W'	T-420-86C	N/R	N/R	N/R	1.317
	3/4	N/R	12 'Z'	T-420-86C	BK/GY	ET420SR-M255A	UP	1.286
H42104	1/4	N/R	04 'Z'	ET400DC-M150S	BK/RD	T-400-47R	UP	.665
H42106	3/8	N/R	06 'Z'	ET400DC-M195S	Yellow	T-400-62	UP	.835
H42504	1/4	N/R	04 'S'	T-400-2C	Black	T-400-10	UP	.610
H42504	1/4	N/R	04 'U'	T-400-2C	Black	T-400-10	UP	.610
	1/4	N/R	04 'W'	T-400-40C	Black	T-400-10	UP	.722
	1/4	N/R	04 'Z'	ET400DC-M150S	Yellow	T-400-62	UP	.665
H42506	3/8	N/R	06 'S'	T-400-3C	Black	T-400-10	UP	.795
	3/8	N/R	06 'U'	T-400-3C	Black	T-400-10	UP	.795
	3/8	N/R	06 'W'	T-400-41C	BK/RD	T-400-47R	UP	.854
	3/8	N/R	06 'Z'	ET400DC-M195S	Yellow	T-400-62	UP	.835
H42508	1/2	N/R	08 'S'	T-400-4C	Black	T-400-10	UP	.920
	1/2	N/R	08 'U'	T-400-4C	Black	T-400-10	UP	.915
	1/2	N/R	08 'W'	T-400-42C	BK/RD	T-400-47R	UP	1.007
	1/2	N/R	08 'Z'	ET400DC-M230S	Black	T-400-10	UP	.990
H42510	5/8	N/R	10 'U'	T-400-64C	Black	T-400-10	UP	1.050
	5/8	N/R	10 'W'	T-420-85C	BK/WH	T-420-80R	UP	1.132
	5/8	N/R	10 'Z'	T-420-85C	BK/WH	T-420-80R	UP	1.130
H42512	3/4	N/R	12 'S'	T-400-5C	Black	T-400-10	UP	1.210
	3/4	N/R	12 'U'	T-400-5C	Black	T-400-10	UP	1.205
	3/4	N/R	43012 'U'	T-420-5CN	N/R	N/R	N/R	1.410
	3/4	N/R	12 'W'	T-420-86C	N/R	N/R-	N/R	1.317
	3/4	N/R	12 'Z'	T-420-86C	BK/GY	ET420SR-M255A	UP	1.280
H42516	1	N/R	16 'S'	T-400-6C	Silver	T-400-11	UP	1.525
	1	N/R	16 'U'	T-400-6C	Silver	T-400-11	UP	1.525
	1	N/R	43016 'U'	T-420-6CN	N/R	N/R	N/R	1.707
	1	N/R	16 'W'	T-420-87C	N/R	N/R	N/R	1.607
	1	N/R	16 'Z'	ET420DC-M380S	N/A	N/A	N/A	1.630
H42520	1-1/4	N/R	20 'S'	T-400-12	Silver	T-400-11	UP	1.885
	1-1/4	N/R	20 'U'	T-400-12	Black	T-400-10	UP	1.850
	1-1/4	N/R	20 'Z'	ET420DC-M480S	N/A	N/A	N/A	1.960
H42908	13/32	N/R	057 'P'	T-400-102C	Green	T-400-37	UP	.660
H42910	1/2	N/R	057 'P'	T-400-103C	Green	T-400-37	UP	.750

Note:
T-420-25 adapter die ring required when using T-400 series collets.

BK=Black **BU**=Blue **OR**=Orange
RD=Red **TN**=Tan **WH**=White
YW=Yellow **SV**=Silver **MG**=Magenta
GY=Gray **GR**=Green **BR**=Brown

Tooling Selector Chart

T-420

HOSE TYPE	HOSE I.D. (IN.)	SKIVE TOOL	HOSE END PREFIX	COLLET PART #	SPACER RING COLOR	SPACER RING PART #	FLAT SIDE UP/DN	NOMINAL CRIMP DIA. (IN.)
H43008	1/2	N/R	43008 'U'	T-420-4CN	N/R	N/R	N/R	1.150
H430R08	1/2	N/R	43008 'U'	T-420-4CN	N/R	N/R	N/R	1.150
H43012	3/4	N/R	43012 'U'	T-420-5CN	N/R	N/R	N/R	1.406
H430R12	3/4	N/R	43012 'U'	T-420-5CN	N/R	N/R	N/R	1.406
H43016	1	N/R	43016 'U'	T-420-6CN	N/R	N/R	N/R	1.705
H430R16	1	N/R	43016 'U'	T-420-6CN	N/R	N/R	N/R	1.705
H43020	1-1/4	N/R	43020 'U'	T-420-7CN	N/R	N/R	N/R	2.035
H430R20	1-1/4	N/R	43020 'U'	T-420-7CN	N/R	N/R	N/R	2.035
H43504	1/4	N/R	04 'E'	T-400-31C	Black	T-400-10	DN	.455
H43505	5/16	N/R	05 'E'	T-400-32C	Black	T-400-10	DN	.555
H43506	3/8	N/R	06 'E'	T-400-33C	Black	T-400-10	DN	.615
H43508	1/2	N/R	08 'E'	T-400-34C	Black	T-400-10	DN	.765
H43512	3/4	N/R	12 'E'	T-400-35C	Black	T-400-10	DN	1.035
H43516	1	N/R	16 'E'	T-400-36C	Black	T-400-10	DN	1.295
H43604	1/4	N/R	04 'E'	T-400-31C	Black	T-400-10	DN	.455
H43605	5/16	N/R	05 'E'	T-400-32C	Black	T-400-10	DN	.555
H43606	3/8	N/R	06 'E'	T-400-33C	Black	T-400-10	DN	.615
H43608	1/2	N/R	08 'E'	T-400-34C	Black	T-400-10	DN	.765
H43612	3/4	N/R	12 'E'	T-400-35C	Black	T-400-10	DN	1.035
H43616	1	N/R	16 'E'	T-400-36C	Black	T-400-10	DN	1.295
H47008	1/2	T-410-50	47008 'E'	T-420-8C	N/R	N/R	N/R	.980
H47012	3/4	T-410-52	47012 'E'	T-420-9C	N/R	N/R	N/R	1.250
	3/4	T-410-52	57012 'S'	T-420-9C	N/R	N/R	N/R	1.250
H47016	1	T-410-53	47016 'E'	T-420-10C	N/R	N/R	N/R	1.560
	1	T-410-53	57016 'S'	T-420-10C	N/R	N/R	N/R	1.560
H47020	1-1/4	T-410-54	47020 'E'	T-420-11	N/R	N/R	N/R	2.025
	1-1/4	T-410-54	57020 'S'	T-420-11	N/R	N/R	N/R	2.025
H54504	1/4	N/R	04 'S'	T-400-2C	Yellow	T-400-62	DN	.560
	1/4	N/R	04 'U'	T-400-2C	Yellow	T-400-62	DN	.560
	1/4	N/R	04 'W'	T-400-40C	Black	T-400-10	DN	.664
H54506	3/8	N/R	06 'S'	T-400-3C	Green	T-400-37	UP	.695
	3/8	N/R	06 'U'	T-400-3C	Green	T-400-37	UP	.695
H54506	3/8	N/R	06 'W'	T-400-41C	Black	T-400-10	DN	.820
H54508	1/2	N/R	08 'M'	T-400-111C	Yellow	T-400-62	UP	.940
	1/2	N/R	08 'S'	T-400-4C	Black	T-400-10	DN	.865
	1/2	N/R	08 'U'	T-400-4C	Yellow	T-400-62	DN	.865
	1/2	N/R	08 'W'	T-400-42C	BK/TN	T-400-46R	UP	.992
H54510	5/8	N/R	10 'U'	T-400-64C	Yellow	T-400-62	UP	1.010
	5/8	N/R	10 'W'	T-420-85C	BK/WH	T-420-80R	UP	1.132
H54512	3/4	N/R	12 'S'	T-400-5C	Yellow	T-400-62	DN	1.155
	3/4	N/R	12 'U'	T-400-5C	Yellow	T-400-62	DN	1.155
	3/4	N/R	12 'W'	T-420-86C	BK/OR	T-420-81R	UP	1.293
H54516	1	N/R	43016 'U'	T-420-6CN	N/R	N/R	N/R	1.705
	1	N/R	16 'W'	T-420-87C	BK/WH	T-420-80R	UP	1.587
H56904	3/16	N/R	06904 'E'	T-400-54C	Yellow	T-400-62	UP	.525
H56905	1/4	N/R	06905 'E'	T-400-55C	Black	T-400-10	UP	.585
H56906	5/16	N/R	06906 'E'	T-400-56C	Black	T-400-10	UP	.680
H56908	13/32	N/R	06908 'E'	T-400-57C	Yellow	T-400-62	UP	.765
H56910	1/2	N/R	06910 'E'	T-400-58C	Black	T-400-10	UP	.910
H56912	5/8	N/R	06912 'E'	T-400-59C	Silver	T-400-11	UP	1.080
H56916	7/8	N/R	06916 'E'	T-400-60C	Black	T-400-10	UP	1.275
H56920	1-1/8	N/R	06920 'E'	T-400-61C	Black	T-400-10	DN	1.485
H75706	5/16	N/R	75706 'E'	T-400-105C	Black	T-400-10	DN	.495
H75708	13/32	N/R	75708 'E'	T-400-106C	Black	T-400-10	DN	.595
H75710	1/2	N/R	75710 'E'	T-400-107C	Black	T-400-10	DN	.695
H75712	5/8	N/R	75712 'E'	T-400-108C	Black	T-400-10	DN	.850
H9610-6	3/8	N/R	06 'Z'	ET400DC-M195S	Purple	ET1000SR-M100A	UP	0.785
H9610-8	1/2	N/R	08 'Z'	ET400DC-M230S	Black	T-400-10	DN	0.940

Note:
T-420-25 adapter die ring required when using T-400 series collets.

BK=Black **BU**=Blue **OR**=Orange
RD=Red **TN**=Tan **WH**=White
YW=Yellow **SV**=Silver **MG**=Magenta
GY=Gray **GR**=Green **BR**=Brown

Tooling Selector Chart

T-480

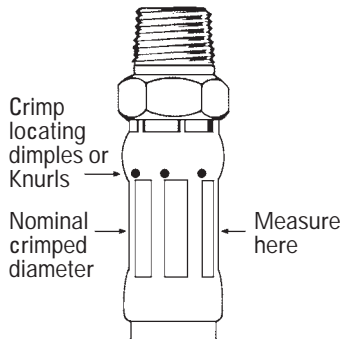
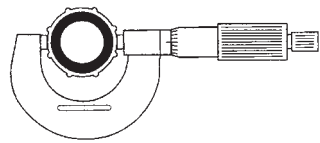

Note:
In larger sizes, calipers may be used; however, in smaller sizes, and in the 'E' Series thermoplastic hose ends, a point micrometer will provide an accurate reading. Nominal crimp diameters are for Weatherhead hose and end fittings when crimped with Weatherhead Coll-O-Crimp tooling.

Note:
T-420-25 adapter die ring required when using T-400 series collets.

⚠ WARNING

Proper Selection of Hose Ends: Selection of the proper end fittings for the hose end application is essential to the proper operation and safe use of the hose and related equipment. Inadequate attention to the selection of the end fittings for your application can result in leaking or the hose ends blowing off the hose, leading to serious bodily injury or property damage. In order to avoid serious bodily injury or property damage resulting from selection of the wrong end fitting, you should carefully review the information in the Weatherhead Catalog W-HYOV-MC002-E.

⚠ WARNING

Coll-O-Crimp Hose, Hose Fittings and Assembly Equipment Compatibility: The Coll-O-Crimp Equipment

Package, Coll-O-Crimp End Fittings, and Coll-O-Crimp Hose have been engineered and designed as a complete hose assembly system. Each component of the Coll-O-Crimp hose assembly system is compatible with other Coll-O-Crimp components to which it relates. Component compatibility, along with the use of quality components, insures the production of reliable hose assemblies when assembled properly. The use or intermixing of fittings and hose not specifically engineered and designed for use with each other and Coll-O-Crimp equipment is not recommended and may result in the production of unsafe or unreliable hose assemblies. This can result in hose assembly leakage, hose separation or other failures which can cause serious bodily injury or property damage from spraying

fluids, flying projectiles, or other substances. Eaton's Weatherhead warranty is limited to apply only when Coll-O-Crimp end fittings and compatible Coll-O-Crimp hose are used with Coll-O-Crimp assembly equipment. **Nominal Crimp Diameter Measurement:** Please remove this chart and place near your Coll-O-Crimp equipment for reference. Measuring crimp diameters should be a part of the normal hose assembly procedure. To insure a proper crimp diameter reading, follow these steps.

1. Measure the diameter in the middle of crimped portion of the hose end.
2. Place the caliper in a position to allow a measurement across the pressed (flat) portion of the crimp.
3. See crimp diameters on following chart.

T-480

HOSE TYPE	HOSE I.D. (IN.)	SKIVE TOOL	HOSE END PREFIX	COLLET PART #	SPACER RING COLOR	SPACER RING PART #	FLAT SIDE UP/DN	NOMINAL CRIMP DIA. (IN.)
H00905	5/16	N/R	05 'E'	T-400-32C	Black	T-400-10	UP	.585
H00906	3/8	N/R	06 'E'	T-400-33C	Black	T-400-10	UP	.655
H00908	1/2	N/R	08 'E'	T-400-34C	Black	T-400-10	UP	.805
H01704	1/4	N/R	04 'U'	T-400-2C	Yellow	T-400-62	UP	.580
H01706	3/8	N/R	06 'U'	T-400-3C	Black	T-400-10	UP	.785
H01708	1/2	N/R	08 'U'	T-400-4C	Silver	T-400-11	UP	.940
H01712	3/4	N/R	12 'U'	T-400-5C	Silver	T-400-11	UP	1.235
H01716	1	N/R	16 'U'	T-400-6C	Silver	T-400-11	UP	1.525
H01720	1-1/4	N/R	20 'U'	T-400-12	Black	T-400-10	DN	1.785
H03912	3/4	N/R	12 'S'	T-400-5C	Silver	T-400-11	UP	1.230
	3/4	N/R	12 'U'	T-400-5C	Silver	T-400-11	UP	1.230
H03916	1	N/R	16 'S'	T-400-6C	Silver	T-400-11	UP	1.520
	1	N/R	16 'U'	T-400-6C	Silver	T-400-11	UP	1.520
H03920	1-1/4	N/R	20 'S'	T-400-12	Black	T-400-10	DN	1.790
	1-1/4	N/R	20 'U'	T-400-12	Black	T-400-10	DN	1.790
H05904	3/16	N/R	06904 'E'	T-400-54C	Yellow	T-400-62	UP	.525
	3/16	N/R	22904 'P'	T-400-80C	Black	T-400-10	DN	.480
H05905	1/4	N/R	06905 'E'	T-400-55C	Black	T-400-10	UP	.585
H05906	5/16	N/R	06906 'E'	T-400-56C	Black	T-400-10	UP	.680

Note:
T-420-25 adapter die ring required when using T-400 series collets.

* Requires use of a new T-480-69 locator bracket.

BK=Black **BU**=Blue **OR**=Orange
RD=Red **TN**=Tan **WH**=White
YW=Yellow **SV**=Silver **MG**=Magenta
GY=Gray **GR**=Green **BR**=Brown

Tooling Selector Chart

T-480

HOSE TYPE	HOSE I.D. (IN.)	SKIVE TOOL	HOSE END PREFIX	COLLET PART #	SPACER RING COLOR	SPACER RING PART #	FLAT SIDE UP/DN	NOMINAL CRIMP DIA. (IN.)
	5/16	N/R	22906 'P'	T-400-81C	Black	T-400-10	DN	.650
H05908	13/32	N/R	06908 'E'	T-400-57C	Yellow	T-400-62	UP	.765
	13/32	N/R	22908 'P'	T-400-82C	Black	T-400-10	DN	.775
H05910	1/2	N/R	06910 'E'	T-400-58C	Black	T-400-10	UP	.910
	1/2	N/R	22910 'P'	T-400-83C	Black	T-400-10	DN	.875
H05912	5/8	N/R	06912 'E'	T-400-59C	Silver	T-400-11	UP	1.080
H05916	7/8	N/R	06916 'E'	T-400-60C	Black	T-400-10	UP	1.275
H06904	3/16	N/R	06904 'E'	T-400-54C	Yellow	T-400-62	UP	.525
H06905	1/4	N/R	06905 'E'	T-400-55C	Black	T-400-10	UP	.585
H06906	5/16	N/R	06906 'E'	T-400-56C	Black	T-400-10	UP	.680
H06908	13/32	N/R	06908 'E'	T-400-57C	Yellow	T-400-62	UP	.765
H06910	1/2	N/R	06910 'E'	T-400-58C	Black	T-400-10	UP	.910
H06912	5/8	N/R	06912 'E'	T-400-59C	Silver	T-400-11	UP	1.080
H06916	7/8	N/R	06916 'E'	T-400-60C	Black	T-400-10	UP	1.275
H06920	1-1/8	N/R	06920 'E'	T-400-61C	Yellow	T-400-62	UP	1.520
H06924	1-3/8	N/R	06924 'E'	T-400-70	Black	T-400-10	UP	1.730
H10404	1/4	N/R	04 'S'	T-400-2C	Black	T-400-10	DN	.561
	1/4	N/R	04 'U'	T-400-2C	Black	T-400-10	DN	.560
	1/4	N/R	04 'W'	T-400-40C	Black	T-400-10	DN	.664
	1/4	N/R	04 'Z'	ET400DC-M150S	Purple	ET1000SR-M100A	UP	0.620
H10406	3/8	N/R	06 'S'	T-400-3C	Black	T-400-10	DN	.740
	3/8	N/R	06 'U'	T-400-3C	Black	T-400-10	DN	.740
	3/8	N/R	06 'W'	T-400-41C	Black	T-400-10	DN	.820
	3/8	N/R	06 'Z'	ET400DC-M195S	Purple	ET1000SR-M100A	UP	0.785
H10408	1/2	N/R	08 'S'	T-400-4C	Black	T-400-10	DN	.863
	1/2	N/R	08 'U'	T-400-4C	Black	T-400-10	DN	.870
	1/2	N/R	08 'W'	T-400-42C	Black	T-400-10	DN	.976
	1/2	N/R	08 'Z'	ET400DC-M230S	Black	T-400-10	DN	0.940
H10410	5/8	N/R	10 'U'	T-400-64C	Black	T-400-10	DN	1.000
	5/8	N/R	10 'W'	T-420-85C	BK/WH	T-420-80R	UP	1.132
	5/8	N/R	10 'Z'	T-420-85C	Pink	ET420SR-M660A	UP	1.055
H10412	3/4	N/R	12 'S'	T-400-5C	Yellow	T-400-62	UP	1.177
	3/4	N/R	12 'U'	T-400-5C	Black	T-400-10	DN	1.160
	3/4	N/R	12 'W'	T-420-86C	BK/BU	T-420-82R	UP	1.260
	3/4	N/R	12 'Z'	T-420-86C	Brown	ET420SR-M495A	UP	1.250
H10416	1	N/R	16 'S'	T-400-6C	Yellow	T-400-62	UP	1.465
	1	N/R	16 'U'	T-400-6C	Black	T-400-10	DN	1.450
	1	N/R	16 'W'	T-420-87C	BK/WH	T-420-80R	UP	1.587
	1	N/R	16 'Z'	ET420DC-M380S	Orange	T-420-29	UP	1.590
H10420	1-1/4	N/R	20 'S'	T-400-12	Black	T-400-10	DN	1.790
	1-1/4	N/R	20 'U'	T-400-12	Black	T-400-10	DN	1.785
H10504	1/4	N/R	04 'U'	T-400-2C	Black	T-400-10	UP	.610
H10506	3/8	N/R	06 'U'	T-400-3C	Black	T-400-10	UP	.788
H10508	1/2	N/R	08 'U'	T-400-4C	Silver	T-400-11	UP	.940
H10512	3/4	N/R	12 'U'	T-400-5C	Silver	T-400-11	UP	1.232
H10516	1	N/R	16 'U'	T-400-6C	Silver	T-400-11	DN	1.435
H11404	1/4	N/R	04 'S'	T-400-2C	Green	T-400-37	UP	.520
	1/4	N/R	04 'U'	T-400-2C	Green	T-400-37	UP	.520
H11406	3/8	N/R	06 'S'	T-400-3C	Green	T-400-37	UP	.695
	3/8	N/R	06 'U'	T-400-3C	Green	T-400-37	UP	.695
H11408	1/2	N/R	08 'S'	T-400-4C	Black	T-400-10	DN	.860
	1/2	N/R	08 'U'	T-400-4C	Green	T-400-37	UP	.830
H11504	1/4	N/R	04 'U'	T-400-2C	Black	T-400-10	UP	.610
H11506	3/8	N/R	06 'U'	T-400-3C	Black	T-400-10	UP	.788
H11508	1/2	N/R	08 'U'	T-400-4C	Silver	T-400-11	UP	.940
H11512	3/4	N/R	12 'U'	T-400-5C	Silver	T-400-11	UP	1.232
H11516	1	N/R	16 'U'	T-400-6C	Silver	T-400-11	UP	1.522
H11520	1-1/4	N/R	20 'U'	T-400-12	Silver	T-400-11	UP	1.862

Note:
T-420-25 adapter die ring required when using T-400 series collets.

* Requires use of a new T-480-69 locator bracket.

BK=Black **BU**=Blue **OR**=Orange
RD=Red **TN**=Tan **WH**=White
YW=Yellow **SV**=Silver **MG**=Magenta
GY=Gray **GR**=Green **BR**=Brown

Tooling Selector Chart

T-480

HOSE TYPE	HOSE I.D. (IN.)	SKIVE TOOL	HOSE END PREFIX	COLLET PART #	SPACER RING COLOR	SPACER RING PART #	FLAT SIDE UP/DN	NOMINAL CRIMP DIA. (IN.)
H14504	1/4	N/R	04 'M'	T-400-109C	Yellow	T-400-62	UP	.630
	1/4	N/R	04 'S'	T-400-2C	Green	T-400-37	UP	.520
H14504	1/4	N/R	04 'U'	T-400-2C	Green	T-400-37	UP	.520
	1/4	N/R	04 'W'	T-400-40C	BK/TN	T-400-46R	UP	.678
	1/4	N/R	04 'Z'	ET400DC-M150S	Purple	ET1000SR-M100A	UP	0.612
H14506	3/8	N/R	06 'M'	T-400-110C	Yellow	T-400-62	UP	.765
	3/8	N/R	06 'S'	T-400-3C	Green	T-400-37	UP	.695
	3/8	N/R	06 'U'	T-400-3C	Green	T-400-37	UP	.695
	3/8	N/R	06 'W'	T-400-41C	Green	T-400-37	UP	.782
	3/8	N/R	06 'Z'	ET400DC-M195S	Green	T-400-37	UP	0.775
H14508	1/2	N/R	08 'M'	T-400-111C	Yellow	T-400-62	UP	.935
	1/2	N/R	08 'S'	T-400-4C	Yellow	T-400-62	DN	.870
	1/2	N/R	08 'U'	T-400-4C	Yellow	T-400-62	DN	.870
	1/2	N/R	08 'W'	T-400-42C	Black	T-400-10	DN	.976
	1/2	N/R	08 'Z'	ET400DC-M230S	Purple	ET1000SR-M100A	UP	0.920
H14510	5/8	N/R	10 'M'	T-420 30C	Orange	T-420-29	UP	1.085
	5/8	N/R	10 'U'	T-400-64C	Yellow	T-400-62	UP	1.010
	5/8	N/R	10 'W'	T-420-85C	Blue#	T-480-68	N/A	1.149
	5/8	N/R	10 'Z'	T-420-85C	BK/GY	ET420SR-M255A	UP	1.115
H14512	3/4	N/R	12 'S'	T-400-5C	Yellow	T-400-62	DN	1.160
	3/4	N/R	12 'U'	T-400-5C	Yellow	T-400-62	DN	1.160
	3/4	N/R	12 'W'	T-420-86C	BK/OR	T-420-81R	UP	1.293
	3/4	N/R	12 'Z'	T-420-86C	Orange	T-420-29	UP	1.275
H14516	1	N/R	16 'S'	T-400-6C	Yellow	T-400-62	DN	1.445
	1	N/R	43016 'U'	T-420-6CN	Orange	T-420-29	UP	1.655
	1	N/R	16 'W'	T-420-87C	BK/WH	T-420-80R	UP	1.587
	1	N/R	16 'Z'	ET420DC-M380S	BK/BU	T-420-82R	UP	1.575
H14604	1/4	N/R	04 'U'	T-400-2C	Green	T-400-37	UP	.520
H14606	3/8	N/R	06 'U'	T-400-3C	Green	T-400-37	UP	.695
H14608	1/2	N/R	08 'U'	T-400-4C	Green	T-400-37	UP	.830
H16604	3/16	N/R	06904 'E'	T-400-54C	Yellow	T-400-62	UP	.525
H16605	1/4	N/R	06905 'E'	T-400-55C	Black	T-400-10	UP	.585
H16606	5/16	N/R	06906 'E'	T-400-56C	Black	T-400-10	UP	.680
H16608	13/32	N/R	06908 'E'	T-400-57C	Yellow	T-400-62	UP	.765
H16610	1/2	N/R	06910 'E'	T-400-58C	Black	T-400-10	UP	.910
H16612	5/8	N/R	06912 'E'	T-400-59C	Silver	T-400-11	UP	1.080
H16616	7/8	N/R	06916 'E'	T-400-60C	Black	T-400-10	UP	1.275
H16620	1-1/8	N/R	06920 'E'	T-400-61C	Yellow	T-400-62	UP	1.520
H16904	3/16	N/R	06904 'E'	T-400-54C	Yellow	T-400-62	UP	.525
H16905	1/4	N/R	06905 'E'	T-400-55C	Black	T-400-10	UP	.585
H16906	5/16	N/R	06906 'E'	T-400-56C	Black	T-400-10	UP	.680
H16908	13/32	N/R	06908 'E'	T-400-57C	Yellow	T-400-62	UP	.765
H16910	1/2	N/R	06910 'E'	T-400-58C	Black	T-400-10	UP	.910
H16912	5/8	N/R	06912 'E'	T-400-59C	Silver	T-400-11	UP	1.080
H16916	7/8	N/R	06916 'E'	T-400-60C	Black	T-400-10	UP	1.275
H16920	1-1/8	N/R	06920 'E'	T-400-61C	Yellow	T-400-62	UP	1.520
H16924	1-3/8	N/R	06924 'E'	T-400-70	Black	T-400-10	UP	1.730
H19004	1/4	N/R	04 'W'	T-400-40C	Black	T-400-10	DN	.664
	1/4	N/R	04 'Z'	ET400DC-M150S	Purple	ET1000SR-M100A	UP	0.620
H19006	3/8	N/R	06 'W'	T-400-41C	Black	T-400-10	DN	.820
	3/8	N/R	06 'Z'	ET400DC-M195S	Purple	ET1000SR-M100A	UP	0.785
H19008	1/2	N/R	08 'W'	T-400-42C	Black	T-400-10	DN	.976
	1/2	N/R	08 'Z'	ET400DC-M230S	Black	T-400-10	DN	0.940
H19010	5/8	N/R	10 'W'	T-420-85C	BK/WH	T-420-80R	UP	1.132
	5/8	N/R	10 'Z'	T-420-85C	Pink	ET420SR-M660A	UP	1.055
H19012	3/4	N/R	12 'W'	T-420-86C	BK/BU	T-420-82R	UP	1.260
	3/4	N/R	12 'Z'	T-420-86C	Brown	ET420SR-M495A	UP	1.250
H19016	1	N/R	16 'W'	T-420-87C	BK/WH	T-420-80R	UP	1.587

Spacer ring is flat on both sides

Note:

T-420-25 adapter die ring required when using T-400 series collets.

* Requires use of a new T-480-69 locator bracket.

BK=Black **BU**=Blue **OR**=Orange
RD=Red **TN**=Tan **WH**=White
YW=Yellow **SV**=Silver **MG**=Magenta
GY=Gray **GR**=Green **BR**=Brown

Tooling Selector Chart

T-480

HOSE TYPE	HOSE I.D. (IN.)	SKIVE TOOL	HOSE END PREFIX	COLLET PART #	SPACER RING COLOR	SPACER RING PART #	FLAT SIDE UP/DN	NOMINAL CRIMP DIA. (IN.)
	1	N/R	16 'Z'	ET420DC-M380S	Orange	T-420-29	UP	1.590
H20904	1/4	N/R	04 'E'	T-400-31C	Black	T-400-10	DN	.455
H20905	5/16	N/R	05 'E'	T-400-32C	Black	T-400-10	DN	.555
H20906	3/8	N/R	06 'E'	T-400-33C	Black	T-400-10	DN	.615
H20908	1/2	N/R	08 'E'	T-400-34C	Black	T-400-10	DN	.765
H22904	3/16	N/R	06904 'E'	T-400-54C	Yellow	T-400-62	UP	.525
	3/16	N/R	22904 'P'	T-400-80C	Yellow	T-400-62	UP	.505
H22906	5/16	N/R	06906 'E'	T-400-56C	Black	T-400-10	UP	.680
	5/16	N/R	22906 'P'	T-400-81C	Black	T-400-10	DN	.650
H22908	13/32	N/R	06908 'E'	T-400-57C	Yellow	T-400-62	UP	.765
	13/32	N/R	22908 'P'	T-400-82C	Black	T-400-10	DN	.775
H22910	1/2	N/R	06910 'E'	T-400-58C	Black	T-400-10	UP	.910
	1/2	N/R	22910 'P'	T-400-83C	Black	T-400-10	DN	.875
H22912	5/8	N/R	06912 'E'	T-400-59C	Silver	T-400-11	UP	1.080
H22916	7/8	N/R	06916 'E'	T-400-60C	Black	T-400-10	UP	1.275
H23904	3/16	N/R	069 'E'	T-400-54C	Yellow	T-400-62	UP	.525
	3/16	N/R	229 'P'	T-400-80C	Black	T-400-10	DN	.480
H23906	5/16	N/R	069 'E'	T-400-56C	Black	T-400-10	UP	.680
	5/16	N/R	229 'P'	T-400-81C	Black	T-400-10	DN	.650
H23908	13/32	N/R	069 'E'	T-400-57C	Yellow	T-400-62	UP	.765
	13/32	N/R	229 'P'	T-400-82C	Black	T-400-10	DN	.775
H23910	1/2	N/R	069 'E'	T-400-58C	Black	T-400-10	UP	.910
	1/2	N/R	229 'P'	T-400-83C	Black	T-400-10	DN	.875
H23912	5/8	N/R	069 'E'	T-400-59C	Silver	T-400-11	UP	1.080
H23916	7/8	N/R	069 'E'	T-400-60C	Black	T-400-10	UP	1.275
H23920	1-1/8	N/R	069 'E'	T-400-61C	Yellow	T-400-62	UP	1.510
H24303	3/16	N/R	03 'E'	T-400-113C	Tan	T-400-112	UP	.355
H24304	1/4	N/R	04 'E'	T-400-31C	Green	T-400-37	UP	.405
H24305	5/16	N/R	05 'E'	T-400-32C	Red	T-400-38	UP	.475
H24306	3/8	N/R	06 'E'	T-400-33C	Red	T-400-38	UP	.545
H24308	1/2	N/R	08 'E'	T-400-34C	Red	T-400-38	UP	.695
H24312	3/4	N/R	12 'E'	T-400-35C	Red	T-400-38	UP	.978
H24316	1	N/R	16 'E'	T-400-36C	Red	T-400-38	UP	1.225
H24504	1/4	N/R	04 'M'	T-400-109C	Black	T-400-10	UP	.665
	1/4	N/R	04 'S'	T-400-2C	Yellow	T-400-62	DN	.560
	1/4	N/R	04 'U'	T-400-2C	Yellow	T-400-62	DN	.560
	1/4	N/R	04 'W'	T-400-40C	BK/TN	T-400-46R	UP	.678
	1/4	N/R	04 'Z'	ET400DC-M150S	BK/TN	T-400-46R	UP	0.650
H24506	3/8	N/R	06 'M'	T-400-110C	Black	T-400-10	UP	.805
	3/8	N/R	06 'S'	T-400-3C	Yellow	T-400-62	DN	.740
	3/8	N/R	06 'U'	T-400-3C	Yellow	T-400-62	DN	.740
	3/8	N/R	06 'W'	T-400-41C	Black	T-400-10	DN	.820
	3/8	N/R	06 'Z'	ET400DC-M195S	Black	T-400-10	DN	0.815
H24508	1/2	N/R	08 'M'	T-400-111C	Yellow	T-400-62	UP	.940
	1/2	N/R	08 'S'	T-400-4C	Yellow	T-400-62	DN	.865
	1/2	N/R	08 'U'	T-400-4C	Yellow	T-400-62	DN	.865
	1/2	N/R	08 'W'	T-400-42C	BK/TN	T-400-46R	UP	.993
	1/2	N/R	08 'Z'	ET400DC-M230S	Lt. Green	ET1000SR-M190D	UP	0.975
H24510	5/8	N/R	10 'M'	T-420-30C	Orange	T-420-29	UP	1.085
	5/8	N/R	10 'U'	T-400-64C	Yellow	T-400-62	UP	1.010
	5/8	N/R	10 'W'	T-420-85C	BK/WH	T-420-80R	UP	1.132
	5/8	N/R	10 'Z'	T-420-85C	BK/GY	ET420SR-M255A	UP	1.115
H24512	3/4	N/R	12 'S'	T-400-5C	Yellow	T-400-62	DN	1.160
	3/4	N/R	12 'U'	T-400-5C	Yellow	T-400-62	DN	1.160
	3/4	N/R	43012 'U'	T-420-5CN	Orange	T-420-29	UP	1.365
	3/4	N/R	12 'W'	T-420-86C	BK/OR	T-420-81R	UP	1.293
	3/4	N/R	12 'Z'	T-420-86C	Brown	ET420SR-M495A	UP	1.245
H24516	1	N/R	16 'S'	T-400-6C	Yellow	T-400-62	UP	1.465

Note:
T-420-25 adapter die ring required when using T-400 series collets.

* Requires use of a new T-480-69 locator bracket.

BK=Black **BU**=Blue **OR**=Orange
RD=Red **TN**=Tan **WH**=White
YW=Yellow **SV**=Silver **MG**=Magenta
GY=Gray **GR**=Green **BR**=Brown

Tooling Selector Chart

T-480

HOSE TYPE	HOSE I.D. (IN.)	SKIVE TOOL	HOSE END PREFIX	COLLET PART #	SPACER RING COLOR	SPACER RING PART #	FLAT SIDE UP/DN	NOMINAL CRIMP DIA. (IN.)
H24516	1	N/R	16 'U'	T-400-6C	Yellow	T-400-62	UP	1.465
	1	N/R	43016 'U'	T-420-6CN	Orange	T-420-29	UP	1.660
	1	N/R	16 'W'	T-420-87C	BK/WH	T-420-80R	UP	1.587
	1	N/R	16 'Z'	ET420DC-M380S	Brown	ET420SR-M495A	UP	1.565
H24520	1-1/4	N/R	20 'S'	T-400-12	Yellow	T-400-62	DN	1.795
	1-1/4	N/R	20 'U'	T-400-12	Yellow	T-400-62	DN	1.795
	1-1/4	N/R	43020 'U'	T-420-7CN	Orange	T-420-29	UP	1.990
	1-1/4	N/R	20 'Z'	ET420DC-M480S	BK/BU	T-420-82R*	UP	1.900
H26504	1/4	N/R	26504 'P'	T-400-2C	Green	T-400-37	UP	.520
H26506	3/8	N/R	06 'E'	T-400-33C	Black	T-400-10	UP	.660
	3/8	N/R	26506 'P'	T-400-2C	Silver	T-400-11	UP	.640
H26508	1/2	N/R	08 'E'	T-400-34C	Black	T-400-10	UP	.810
H26508	1/2	N/R	26508 'P'	T-400-3C	Black	T-400-10	UP	.788
H26512	3/4	N/R	12 'E'	T-400-35C	Black	T-400-10	UP	1.090
	3/4	N/R	26512 'P'	T-400-64C	Silver	T-400-11	UP	1.070
H26516	1	N/R	16 'E'	T-400-36C	Black	T-400-10	UP	1.340
H27504	1/4	N/R	26504 'P'	T-400-2C	Green	T-400-37	UP	.520
H27506	3/8	N/R	06 'E'	T-400-33C	Black	T-400-10	UP	.660
	3/8	N/R	26506 'P'	T-400-2C	Silver	T-400-11	UP	.640
H27508	1/2	N/R	08 'E'	T-400-34C	Black	T-400-10	UP	.810
	1/2	N/R	26508 'P'	T-400-3C	Black	T-400-10	UP	.788
H27512	3/4	N/R	12 'E'	T-400-35C	Black	T-400-10	UP	1.090
	3/4	N/R	26512 'P'	T-400-64C	Silver	T-400-11	UP	1.070
H27516	1	N/R	16 'E'	T-400-36C	Black	T-400-10	UP	1.340
H27703	3/16	N/R	03 'E'	T-400-113C	Tan	T-400-112	UP	.355
H27704	1/4	N/R	04 'E'	T-400-31C	Green	T-400-37	UP	.405
H27705	5/16	N/R	05 'E'	T-400-32C	Red	T-400-38	UP	.475
H27706	3/8	N/R	06 'E'	T-400-33C	Red	T-400-38	UP	.545
H27708	1/2	N/R	08 'E'	T-400-34C	Red	T-400-38	UP	.695
H27712	3/4	N/R	12 'E'	T-400-35C	Red	T-400-38	UP	.978
H27716	1	N/R	16 'E'	T-400-36C	Red	T-400-38	UP	1.225
H28004	1/4	N/R	04 'W'	T-400-40C	BK/TN	T-400-46R	UP	.678
	1/4	N/R	04 'Z'	ET400DC-M150S	Yellow	T-400-62	UP	0.665
H28006	3/8	N/R	06 'W'	T-400-41C	Black	T-400-10	DN	.820
	3/8	N/R	06 'Z'	ET400DC-M195S	Black	T-400-10	DN	0.815
H28008	1/2	N/R	08 'W'	T-400-42C	BK/TN	T-400-46R	UP	.992
	1/2	N/R	08 'Z'	ET400DC-M230S	Lt. Green	ET1000SR-M190D	UP	0.975
H28010	5/8	N/R	10 'W'	T-420-85C	BK/WH	T-420-80R	UP	1.132
	5/8	N/R	10 'Z'	T-420-85C	BK/GY	ET420SR-M255A	UP	1.115
H28012	3/4	N/R	12 'W'	T-420-86C	BK/OR	T-420-81R	UP	1.293
	3/4	N/R	12 'Z'	T-420-86C	Brown	ET420SR-M495A	UP	1.245
H28016	1	N/R	16 'W'	T-420-87C	BK/WH	T-420-80R	UP	1.587
	1	N/R	16 'Z'	ET420DC-M380S	Brown	ET420SR-M495A	UP	1.565
H28020	1-1/4	N/R	20 'Z'	ET420DC-M480S	BK/BU	T-420-82R*	UP	1.900
H28504	1/4	N/R	04 'E'	T-400-31C	Black	T-400-10	UP	.500
	1/4	N/R	26504 'P'	T-400-2C	Green	T-400-37	UP	.520
H28506	3/8	N/R	06 'E'	T-400-33C	Black	T-400-10	UP	.660
	3/8	N/R	26506 'P'	T-400-2C	Silver	T-400-11	UP	.640
H28508	1/2	N/R	08 'E'	T-400-34C	Black	T-400-10	UP	.810
	1/2	N/R	26508 'P'	T-400-3C	Black	T-400-10	UP	.788
H28512	3/4	N/R	12 'E'	T-400-35C	Black	T-400-10	UP	1.090
	3/4	N/R	26512 'P'	T-400-64C	Silver	T-400-11	UP	1.070
H28516	1	N/R	16 'E'	T-400-36C	Black	T-400-10	UP	1.340
H29004	1/4	N/R	04 'W'	T-400-40C	Black	T-400-10	UP	.722
	1/4	N/R	04 'Z'	ET400DC-M150S	Lt. Green	ET1000SR-M190D	UP	0.680
H29006	3/8	N/R	06 'W'	T-400-41C	BK/RD	T-400-47R	UP	.854
	3/8	N/R	06 'Z'	ET400DC-M195S	Yellow	T-400-62	UP	0.835
H29008	1/2	N/R	08 'W'	T-400-42C	BK/RD	T-400-47R	UP	1.007

Spacer ring is flat on both sides

Note:

T-420-25 adapter die ring required when using T-400 series collets.

* Requires use of a new T-480-69 locator bracket.

BK=Black **BU**=Blue **OR**=Orange
RD=Red **TN**=Tan **WH**=White
YW=Yellow **SV**=Silver **MG**=Magenta
GY=Gray **GR**=Green **BR**=Brown

Tooling Selector Chart

T-480

HOSE TYPE	HOSE I.D. (IN.)	SKIVE TOOL	HOSE END PREFIX	COLLET PART #	SPACER RING COLOR	SPACER RING PART #	FLAT SIDE UP/DN	NOMINAL CRIMP DIA. (IN.)
	1/2	N/R	08 'Z'	ET400DC-M230S	Black	T-400-10	UP	0.990
H29010	5/8	N/R	10 'W'	T-420-85C	Blue#	T-480-68	N/A	1.149
	5/8	N/R	10 'Z'	T-420-85C	BK/WH	T-420-80R	UP	1.130
H29012	3/4	N/R	12 'W'	T-420-86C	Blue#	T-480-68	N/A	1.317
	3/4	N/R	12 'Z'	T-420-86C	BK/GY	ET420SR-M255A	UP	1.280
H29016	1	N/R	16 'W'	T-420-87C	Blue#	T-480-68	N/A	1.607
	1	N/R	16 'Z'	ET420DC-M380S	Blue#	T-480-68	N/A	1.630
H29020	1-1/4	N/R	20 'Z'	ET420DC-M480S	Blue#	ET1000C-0012*	N/A	1.960
H32406	3/8	N/R	06 'U'	T-400-3C	Black	T-400-10	UP	.785
H32504	1/4	N/R	04 'U'	T-400-2C	Black	T-400-10	UP	.610
H32506	3/8	N/R	06 'U'	T-400-3C	Black	T-400-10	UP	.795
H32508	1/2	N/R	08 'U'	T-400-4C	Yellow	T-400-62	UP	.885
H32512	3/4	N/R	12 'U'	T-400-5C	Black	T-400-10	UP	1.215
H32516	1	N/R	16 'U'	T-400-6C	Silver	T-400-11	UP	1.525
H33503	3/16	N/R	33603 'E'	T-400-120C	Black	T-400-10	UP	.540
H33504	1/4	N/R	33604 'E'	T-400-121C	Black	T-400-10	UP	.667
H33506	3/8	N/R	33606 'E'	T-400-122C	Black	T-400-10	UP	.770
H33508	1/2	N/R	33608 'E'	T-400-123C	Black	T-400-10	UP	.895
H33512	3/4	N/R	33612 'E'	T-420-15C	Black	T-400-10	UP	1.115
H33516	1	N/R	33616 'E'	T-420-16C	Black	T-400-10	UP	1.455
H33603	3/16	N/R	33603 'E'	T-400-120C	Black	T-400-10	UP	.540
H33604	1/4	N/R	33604 'E'	T-400-121C	Black	T-400-10	UP	.667
H33606	3/8	N/R	33606 'E'	T-400-122C	Black	T-400-10	UP	.770
H33608	1/2	N/R	33608 'E'	T-400-123C	Black	T-400-10	UP	.895
H33612	3/4	N/R	33612 'E'	T-420-15C	Black	T-400-10	UP	1.115
H33616	1	N/R	33616 'E'	T-420-16C	Black	T-400-10	UP	1.455
H33806	3/8	N/R	33806 'P'	T-400-102C	Black	T-400-10	DN	.700
H33808	1/2	N/R	33808 'P'	T-400-103C	Black	T-400-10	DN	.795
H34504	1/4	N/R	04 'M'	T-400-109C	Yellow	T-400-62	UP	.630
	1/4	N/R	04 'W'	T-400-40C	Black	T-400-10	DN	.664
	1/4	N/R	04 'Z'	ET400DC-M150S	Tan	T-400-112	UP	0.625
H34506	3/8	N/R	06 'M'	T-400-110C	Yellow	T-400-62	UP	.765
	3/8	N/R	06 'W'	T-400-41C	Green	T-400-37	UP	.782
	3/8	N/R	06 'Z'	ET400DC-M195S	Green	T-400-37	UP	0.775
H34508	1/2	N/R	08 'M'	T-400-111C	Yellow	T-400-62	DN	.915
	1/2	N/R	08 'W'	T-400-42C	Black	T-400-10	DN	.976
	1/2	N/R	08 'Z'	ET400DC-M230S	Black	T-400-10	DN	0.940
H35006	3/8	N/R	06 'M'	T-400-110C	Black	T-400-10	UP	.805
	3/8	N/R	06 'W'	T-400-41C	Black	T-400-10	DN	.820
	3/8	N/R	06 'U'	T-400-3C	Yellow	T-400-62	DN	.740
	3/8	N/R	06 'Z'	ET400DC-M195S	Black	T-400-10	DN	0.815
H35008	1/2	N/R	08 'M'	T-400-111C	Yellow	T-400-62	UP	.945
	1/2	N/R	08 'W'	T-400-42C	BK/TN	T-400-46R	UP	.993
	1/2	N/R	08 'U'	T-400-4C	Yellow	T-400-62	DN	.865
	1/2	N/R	08 'Z'	ET400DC-M230S	Lt. Green	ET1000SR-M190D	UP	0.975
H35010	5/8	N/R	10 'M'	T-420-30C	Blue#	T-480-68	N/A	1.120
	5/8	N/R	10 'W'	T-420-85C	BK/WH	T-420-80R	UP	1.132
	5/8	N/R	10 'Z'	T-420-85C	BK/WH	T-420-80R	UP	1.130
H35012	3/4	N/R	43012 'U'	T-420-5CN	Blue#	T-480-68	N/A	1.413
H35016	1	N/R	43016 'U'	T-420-6CN	Blue#	T-480-68	N/A	1.705
H36606	5/16	N/R	06906 'E'	T-400-56C	Black	T-400-10	UP	.680
H36608	13/32	N/R	06908 'E'	T-400-57C	Yellow	T-400-62	UP	.765
H40010	5/8	N/R	10 'W'	T-420-85C	Blue#	T-480-68	N/A	1.149
	5/8	N/R	10 'Z'	T-420-85C	BK/WH	T-420-80R	UP	1.129
H40012	3/4	N/R	12 'W'	T-420-86C	Blue#	T-480-68	N/A	1.317
	3/4	N/R	12 'Z'	T-420-86C	BK/GY	ET420SR-M255A	UP	1.286
H42504	1/4	N/R	04 'S'	T-400-2C	Black	T-400-10	UP	.610
	1/4	N/R	04 'U'	T-400-2C	Black	T-400-10	UP	.610

Spacer ring is flat on both sides

Note:

T-420-25 adapter die ring required when using T-400 series collets.

* Requires use of a new T-480-69 locator bracket.

BK=Black **BU**=Blue **OR**=Orange
RD=Red **TN**=Tan **WH**=White
YW=Yellow **SV**=Silver **MG**=Magenta
GY=Gray **GR**=Green **BR**=Brown

Tooling Selector Chart

T-480

HOSE TYPE	HOSE I.D. (IN.)	SKIVE TOOL	HOSE END PREFIX	COLLET PART #	SPACER RING COLOR	SPACER RING PART #	FLAT SIDE UP/DN	NOMINAL CRIMP DIA. (IN.)
	1/4	N/R	04 'W'	T-400-40C	Black	T-400-10	UP	.722
	1/4	N/R	04 'Z'	ET400DC-M150S	Yellow	T-400-62	UP	0.665
H42506	3/8	N/R	06 'S'	T-400-3C	Black	T-400-10	UP	.795
	3/8	N/R	06 'U'	T-400-3C	Black	T-400-10	UP	.795
	3/8	N/R	06 'W'	T-400-41C	BK/RD	T-400-47R	UP	.854
	3/8	N/R	06 'Z'	ET400DC-M195S	Yellow	T-400-62	UP	0.835
H42508	1/2	N/R	08 'S'	T-400-4C	Black	T-400-10	UP	.920
	1/2	N/R	08 'U'	T-400-4C	Black	T-400-10	UP	.915
	1/2	N/R	08 'W'	T-400-42C	BK/RD	T-400-47R	UP	1.007
	1/2	N/R	08 'Z'	ET400DC-M230S	Black	T-400-10	UP	0.990
H42510	5/8	N/R	10 'U'	T-400-64C	Black	T-400-10	UP	1.050
	5/8	N/R	10 'W'	T-420-85C	BK/WH	T-420-80R	UP	1.132
	5/8	N/R	10 'Z'	T-420-85C	BK/WH	T-420-80R	UP	1.130
H42512	3/4	N/R	12 'S'	T-400-5C	Black	T-400-10	UP	1.210
	3/4	N/R	12 'U'	T-400-5C	Black	T-400-10	UP	1.205
	3/4	N/R	43012 'U'	T-420-5CN	Blue#	T-480-68	N/A	1.410
	3/4	N/R	12 'W'	T-420-86C	Blue#	T-480-68	N/A	1.317
	3/4	N/R	12 'Z'	T-420-86C	BK/GY	ET420SR-M255A	UP	1.280
H42516	1	N/R	16 'S'	T-400-6C	Silver	T-400-11	UP	1.525
	1	N/R	16 'U'	T-400-6C	Silver	T-400-11	UP	1.525
	1	N/R	43016 'U'	T-420-6CN	Blue#	T-480-68	N/A	1.707
	1	N/R	16 'W'	T-420-87C	Blue#	T-480-68	N/A	1.607
	1	N/R	16 'Z'	ET420DC-M380S	Blue	T-480-68	N/A	1.630
H42520	1-1/4	N/R	20 'S'	T-400-12	Silver	T-400-11	UP	1.885
	1-1/4	N/R	20 'U'	T-400-12	Black	T-400-10	UP	1.850
	1-1/4	N/R	20 'Z'	ET420DC-M480S	Blue#	ET1000C-0012*	N/A	1.960
H42908	13/32	N/R	057 'P'	T-400-102C	Green	T-400-37	UP	.660
H42910	1/2	N/R	057 'P'	T-400-103C	Green	T-400-37	UP	.750
H43008	1/2	N/R	43008 'U'	T-420-4CN	Blue#	T-480-68	N/A	1.150
H430R08	1/2	N/R	430 'U'	T-420-4CN	Blue	T-480-68	N/A	1.150
H43012	3/4	N/R	43012 'U'	T-420-5CN	Blue#	T-480-68	N/A	1.406
H430R12	3/4	N/R	430 'U'	T-420-5CN	Blue	T-480-68	N/A	1.406
H43016	1	N/R	43016 'U'	T-420-6CN	Blue#	T-480-68	N/A	1.705
H430R16	1	N/R	430 'U'	T-420-6CN	Blue	T-480-68	N/A	1.705
H43020	1-1/4	N/R	43020 'U'	T-420-7CN	Blue#	T-480-68	N/A	2.035
H430R20	1-1/4	N/R	430 'U'	T-420-7CN	Blue	T-480-68	N/A	2.035
H43504	1/4	N/R	04 'E'	T-400-31C	Black	T-400-10	DN	.455
H43505	5/16	N/R	05 'E'	T-400-32C	Black	T-400-10	DN	.555
H43506	3/8	N/R	06 'E'	T-400-33C	Black	T-400-10	DN	.615
H43508	1/2	N/R	08 'E'	T-400-34C	Black	T-400-10	DN	.765
H43512	3/4	N/R	12 'E'	T-400-35C	Black	T-400-10	DN	1.035
H43516	1	N/R	16 'E'	T-400-36C	Black	T-400-10	DN	1.295
H43604	1/4	N/R	04 'E'	T-400-31C	Black	T-400-10	DN	.455
H43605	5/16	N/R	05 'E'	T-400-32C	Black	T-400-10	DN	.555
H43606	3/8	N/R	06 'E'	T-400-33C	Black	T-400-10	DN	.615
H43608	1/2	N/R	08 'E'	T-400-34C	Black	T-400-10	DN	.765
H43612	3/4	N/R	12 'E'	T-400-35C	Black	T-400-10	DN	1.035
H43616	1	N/R	16 'E'	T-400-36C	Black	T-400-10	DN	1.295
H47008	1/2	T-410-50	47008 'E'	T-420-8C	Blue#	T-480-68	N/A	.980
H47012	3/4	T-410-52	47012 'E'	T-420-9C	Blue#	T-480-68	N/A	1.250
	3/4	T-410-52	57012 'S'	T-420-9C	Blue#	T-480-68	N/A	1.250
H47016	1	T-410-53	47016 'E'	T-420-10C	Blue#	T-480-68	N/A	1.560
	1	T-410-53	57016 'S'	T-420-10C	Blue#	T-480-68	N/A	1.560
H47020	1-1/4	T-410-54	47020 'E'	T-420-11	Blue#	T-480-68	N/A	2.025
	1-1/4	T-410-54	57020 'S'	T-420-11	Blue#	T-480-68	N/A	2.025
H54504	1/4	N/R	04 'S'	T-400-2C	Yellow	T-400-62	DN	.560
	1/4	N/R	04 'U'	T-400-2C	Yellow	T-400-62	DN	.560
	1/4	N/R	04 'W'	T-400-40C	Black	T-400-10	DN	.664

Note:

T-420-25 adapter die ring required when using T-400 series collets.

* Requires use of a new T-480-69 locator bracket.

BK=Black **BU**=Blue **OR**=Orange
RD=Red **TN**=Tan **WH**=White
YW=Yellow **SV**=Silver **MG**=Magenta
GY=Gray **GR**=Green **BR**=Brown

Tooling Selector Chart

T-480

HOSE TYPE	HOSE I.D. (IN.)	SKIVE TOOL	HOSE END PREFIX	COLLET PART #	SPACER RING COLOR	SPACER RING PART #	FLAT SIDE UP/DN	NOMINAL CRIMP DIA. (IN.)
H54506	3/8	N/R	06 'S'	T-400-3C	Green	T-400-37	UP	.695
H54506	3/8	N/R	06 'U'	T-400-3C	Green	T-400-37	UP	.695
	3/8	N/R	06 'W'	T-400-41C	Black	T-400-10	DN	.820
H54508	1/2	N/R	08 'M'	T-400-111C	Yellow	T-400-62	UP	.940
	1/2	N/R	08 'S'	T-400-4C	Black	T-400-10	DN	.865
	1/2	N/R	08 'U'	T-400-4C	Yellow	T-400-62	DN	.865
	1/2	N/R	08 'W'	T-400-42C	BK/TN	T-400-46R	UP	.992
H54510	5/8	N/R	10 'U'	T-400-64C	Yellow	T-400-62	UP	1.010
	5/8	N/R	10 'W'	T-420-85C	BK/WH	T-420-80R	UP	1.132
H54512	3/4	N/R	12 'S'	T-400-5C	Yellow	T-400-62	DN	1.155
	3/4	N/R	12 'U'	T-400-5C	Yellow	T-400-62	DN	1.155
	3/4	N/R	12 'W'	T-420-86C	BK/OR	T-420-81R	UP	1.293
H54516	1	N/R	43016 'U'	T-420-6CN	Blue#	T-480-68	N/A	1.705
	1	N/R	16 'W'	T-420-87C	BK/WH	T-420-80R	UP	1.587
H56904	3/16	N/R	06904 'E'	T-400-54C	Yellow	T-400-62	UP	.525
H56905	1/4	N/R	06905 'E'	T-400-55C	Black	T-400-10	UP	.585
H56906	5/16	N/R	06906 'E'	T-400-56C	Black	T-400-10	UP	.680
H56908	13/32	N/R	06908 'E'	T-400-57C	Yellow	T-400-62	UP	.765
H56910	1/2	N/R	06910 'E'	T-400-58C	Black	T-400-10	UP	.910
H56912	5/8	N/R	06912 'E'	T-400-59C	Silver	T-400-11	UP	1.080
H56916	7/8	N/R	06916 'E'	T-400-60C	Black	T-400-10	UP	1.275
H56920	1-1/8	N/R	06920 'E'	T-400-61C	Black	T-400-10	DN	1.485
H75706	5/16	N/R	75706 'E'	T-400-105C	Black	T-400-10	DN	.495
H75708	13/32	N/R	75708 'E'	T-400-106C	Black	T-400-10	DN	.595
H75710	1/2	N/R	75710 'E'	T-400-107C	Black	T-400-10	DN	.695
H75712	5/8	N/R	75712 'E'	T-400-108C	Black	T-400-10	DN	.850
H9610-6	3/8	N/R	06 'Z'	ET400DC-M195S	Purple	ET1000SR-M100A	UP	0.785
H9610-8	1/2	N/R	08 'Z'	ET400DC-M230S	Black	T-400-10	DN	0.940

Note:
T-420-25 adapter die ring required when using T-400 series collets.

* Requires use of a new T-480-69 locator bracket.

BK=Black **BU**=Blue **OR**=Orange
RD=Red **TN**=Tan **WH**=White
YW=Yellow **SV**=Silver **MG**=Magenta
GY=Gray **GR**=Green **BR**=Brown

Tooling Selector Chart

T-410

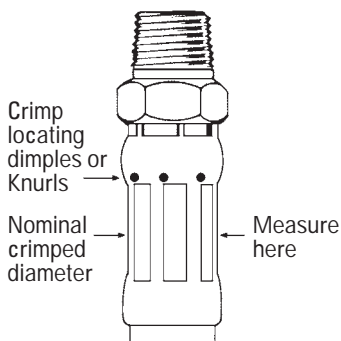
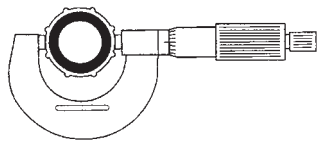

Note:

In larger sizes, calipers may be used; however, in smaller sizes, and in the 'E' Series thermoplastic hose ends, a point micrometer will provide an accurate reading. Nominal crimp diameters are for Weatherhead hose and end fittings when crimped with Weatherhead Coll-O-Crimp tooling.

Note:

T-410-25 adapter die ring required when using T-400 series collets.

⚠ WARNING

Proper Selection of Hose Ends: Selection of the proper end fittings for the hose end application is essential to the proper operation and safe use of the hose and related equipment. Inadequate attention to the selection of the end fittings for your application can result in leaking or the hose ends blowing off the hose, leading to serious bodily injury or property damage. In order to avoid serious bodily injury or property damage resulting from selection of the wrong end fitting, you should carefully review the information in the Weatherhead Catalog W-HYOV-MC002-E.

⚠ WARNING

Coll-O-Crimp Hose, Hose Fittings and Assembly Equipment Compatibility: The Coll-O-Crimp Equipment Package, Coll-O-Crimp End Fittings, and Coll-O-Crimp Hose have been engineered

and designed as a complete hose assembly system. Each component of the Coll-O-Crimp hose assembly system is compatible with other Coll-O-Crimp components to which it relates. Component compatibility, along with the use of quality components, insures the production of reliable hose assemblies when assembled properly. The use or intermixing of fittings and hose not specifically engineered and designed for use with each other and Coll-O-Crimp equipment is not recommended and may result in the production of unsafe or unreliable hose assemblies. This can result in hose assembly leakage, hose separation or other failures which can cause serious bodily injury or property damage from spraying fluids, flying projectiles, or other substances. Eaton's Weatherhead warranty is limited to apply only when Coll-O-Crimp end fittings and compatible Coll-O-Crimp

hose are used with Coll-O-Crimp assembly equipment.

Nominal Crimp Diameter Measurement:

Please remove this chart and place near your Coll-O-Crimp equipment for reference. Measuring crimp diameters should be a part of the normal hose assembly procedure. To insure a proper crimp diameter reading, follow these steps.

1. Measure the diameter in the middle of crimped portion of the hose end.
2. Place the caliper in a position to allow a measurement across the pressed (flat) portion of the crimp.
3. See crimp diameters on following chart.

HOSE TYPE	HOSE I.D. (IN.)	SKIVE TOOL	HOSE END PREFIX	COLLET PART #	SPACER RING COLOR	SPACER RING PART #	FLAT SIDE UP/DN	NOMINAL CRIMP DIA. (IN.)
H00905	5/16	N/R	05 'E'	T-400-32C	Black	T-410-10	UP	.585
H00906	3/8	N/R	06 'E'	T-400-33C	Black	T-410-10	UP	.655
H00908	1/2	N/R	08 'E'	T-400-34C	Black	T-410-10	UP	.805
H01704	1/4	N/R	04 'U'	T-400-2C	Yellow	T-410-41	UP	.580
H01706	3/8	N/R	06 'U'	T-400-3C	Black	T-410-10	UP	.785
H01708	1/2	N/R	08 'U'	T-400-4C	Silver	T-410-11	UP	.940
H01712	3/4	N/R	12 'U'	T-400-5C	Silver	T-410-11	UP	1.235
H01716	1	N/R	16 'U'	T-400-6C	Silver	T-410-11	UP	1.525
H01720	1-1/4	N/R	20 'U'	T-400-12	Black	T-410-10	DN	1.785
H03912	3/4	N/R	12 'S'	T-400-5C	Silver	T-410-11	UP	1.230
	3/4	N/R	12 'U'	T-400-5C	Silver	T-410-11	UP	1.230
	3/4	N/R	12 'Z'	T-410-5CN	Tan	T-410-42	UP	1.401
H03912	3/4	N/R	12 'Z'	T-410-5CN	Tan	T-410-42	UP	1.401
H03916	1	N/R	16 'S'	T-400-6C	Silver	T-410-11	UP	1.520
	1	N/R	16 'U'	T-400-6C	Silver	T-410-11	UP	1.520
	1	N/R	16 'Z'	T-410-6CN	N/R	N/R	N/R	1.708

Note:

T-410-25 adapter die ring required when using T-400 series collets.

BK=Black **BU**=Blue **OR**=Orange
RD=Red **TN**=Tan **WH**=White
YW=Yellow **SV**=Silver **MG**=Magenta
GY=Gray **GR**=Green **BR**=Brown

Tooling Selector Chart

T-410

HOSE TYPE	HOSE I.D. (IN.)	SKIVE TOOL	HOSE END PREFIX	COLLET PART #	SPACER RING COLOR	SPACER RING PART #	FLAT SIDE UP/DN	NOMINAL CRIMP DIA. (IN.)
H039H16	1	N/R	16 'Z'	T-410-6CN	N/R	N/R	N/R	1.708
H03920	1-1/4	N/R	20 'S'	T-400-12	Black	T-410 -10	DN	1.790
	1-1/4	N/R	20 'U'	T-400-12	Black	T-410 -10	DN	1.790
	1-1/4	N/R	20 'Z'	T-400-7CN	N/R	N/R	N/R	2.028
H039H20	1-1/4	N/R	20 'Z'	T-400-7CN	N/R	N/R	N/R	2.028
H03924	1-1/2	N/R	43024 'U'	T-410-8N	N/R	N/R	N/R	2.285
	1-1/2	N/R	24 'Z'	ET4000DC-M560S	N/R	N/R	N/R	2.291
H039H24	1-1/2	N/R	24 'Z'	ET4000DC-M560S	N/R	N/R	N/R	2.291
H03932	2	N/R	43032 'U'	T-410-9N	N/R	N/R	N/R	2.895
	2	N/R	32'Z'	ET4000DC-M560S	N/R	N/R	N/R	2.768
H039H32	2	N/R	32'Z'	ET4000DC-M560S	N/R	N/R	N/R	2.768
H05904	3/16	N/R	06904 'E'	T-400-54C	Yellow	T-410 -41	UP	.525
	3/16	N/R	22904 'P'	T-400-80C	Black	T-410 -10	DN	.480
H05905	1/4	N/R	06905 'E'	T-400-55C	Black	T-410 -10	UP	.585
H05906	5/16	N/R	06906 'E'	T-400-56C	Black	T-410 -10	UP	.680
	5/16	N/R	22906 'P'	T-400-81C	Black	T-410 -10	DN	.650
H05908	13/32	N/R	06908 'E'	T-400-57C	Yellow	T-410-41	UP	.765
H05908	13/32	N/R	22908 'P'	T-400-82C	Black	T-410-10	DN	.775
H05910	1/2	N/R	06910 'E'	T-400-58C	Black	T-410-10	UP	.910
	1/2	N/R	22910 'P'	T-400-83C	Black	T-410-10	DN	.875
H05912	5/8	N/R	06912 'E'	T-400-59C	Silver	T-410-11	UP	1.080
H05916	7/8	N/R	06916 'E'	T-400-60C	Black	T-410-10	UP	1.275
H06904	3/16	N/R	06904 'E'	T-400-54C	Yellow	T-410-41	UP	.525
H06905	1/4	N/R	06905 'E'	T-400-55C	Black	T-410-10	UP	.585
H06906	5/16	N/R	06906 'E'	T-400-56C	Black	T-410-10	UP	.680
H06908	13/32	N/R	06908 'E'	T-400-57C	Yellow	T-410-41	UP	.765
H06910	1/2	N/R	06910 'E'	T-400-58C	Black	T-410-10	UP	.910
H06912	5/8	N/R	06912 'E'	T-400-59C	Silver	T-410-11	UP	1.080
H06916	7/8	N/R	06916 'E'	T-400-60C	Black	T-410-10	UP	1.275
H06920	1-1/8	N/R	06920 'E'	T-400-61C	Yellow	T-410-41	UP	1.520
H06924	1-3/8	N/R	06924 'E'	T-400-70	Black	T-410-10	UP	1.730
H06932	1-13/16	N/R	06932 'E'	T-410-71C	N/R	N/R	N/R	2.202
H10404	1/4	N/R	04 'S'	T-400-2C	Black	T-410-10	DN	.561
	1/4	N/R	04 'U'	T-400-2C	Black	T-410-10	DN	.560
	1/4	N/R	04 'W'	T-400-40C	Black	T-410-10	DN	.664
	1/4	N/R	04 'Z'	ET400DC-M150S	Purple	ET4000SR-M100A	UP	0.620
H10406	3/8	N/R	06 'S'	T-400-3C	Black	T-410-10	DN	.740
	3/8	N/R	06 'U'	T-400-3C	Black	T-410-10	DN	.740
	3/8	N/R	06 'W'	T-400-41C	Black	T-410-10	DN	.820
	3/8	N/R	06 'Z'	ET400DC-M195S	Purple	ET4000SR-M100A	UP	0.785
H10408	1/2	N/R	08 'S'	T-400-4C	Black	T-410-10	DN	.863
	1/2	N/R	08 'U'	T-400-4C	Black	T-410-10	DN	.870
	1/2	N/R	08 'W'	T-400-42C	Black	T-410-10	DN	.976
	1/2	N/R	08 'Z'	ET400DC-M230S	Black	T-410-10	DN	0.940
H10410	5/8	N/R	10 'U'	T-400-64C	Black	T-410-10	DN	1.000
	5/8	N/R	10 'W'	T-440-85C	BK/WH	T-440-80R	UP	1.132
	5/8	N/R	10 'Z'	T-440-85C	Pink	ET4000SR-M560A	UP	1.055
H10412	3/4	N/R	12 'S'	T-400-5C	Yellow	T-410-41	UP	1.177
	3/4	N/R	12 'U'	T-400-5C	Black	T-410-10	DN	1.160
	3/4	N/R	12 'W'	T-440-86C	BK/BU	T-440-82R	UP	1.260
	3/4	N/R	12 'Z'	T-440-86C	Brown	ET4000SR-M405A	UP	1.250
H10416	1	N/R	16 'S'	T-400-6C	Yellow	T-410-41	UP	1.465
	1	N/R	16 'U'	T-400-6C	Black	T-410-10	DN	1.450
	1	N/R	16 'W'	T-440-87C	BK/WH	T-440-80R	UP	1.587
	1	N/R	16 'Z'	ET4000DC-M380S	Orange	T-410-93	UP	1.590
H10420	1-1/4	N/R	20 'S'	T-400-12	Black	T-410-10	DN	1.790
	1-1/4	N/R	20 'U'	T-400-12	Black	T-410-10	DN	1.785
H10504	1/4	N/R	04 'U'	T-400-2C	Black	T-410-10	UP	.610
H10506	3/8	N/R	06 'U'	T-400-3C	Black	T-410-10	UP	.788

Note:
T-410-25 adapter die ring required when using T-400 series collets.

BK=Black **BU**=Blue **OR**=Orange
RD=Red **TN**=Tan **WH**=White
YW=Yellow **SV**=Silver **MG**=Magenta
GY=Gray **GR**=Green **BR**=Brown

Tooling Selector Chart

T-410

HOSE TYPE	HOSE I.D. (IN.)	SKIVE TOOL	HOSE END PREFIX	COLLET PART #	SPACER RING COLOR	SPACER RING PART #	FLAT SIDE UP/DN	NOMINAL CRIMP DIA. (IN.)
H10508	1/2	N/R	08 'U'	T-400-4C	Silver	T-410-11	UP	.940
H10512	3/4	N/R	12 'U'	T-400-5C	Silver	T-410-11	UP	1.232
H10516	1	N/R	16 'U'	T-400-6C	Silver	T-410-11	DN	1.435
H11404	1/4	N/R	04 'S'	T-400-2C	Green	T-410-39	UP	.520
	1/4	N/R	04 'U'	T-400-2C	Green	T-410-39	UP	.520
H11406	3/8	N/R	06 'S'	T-400-3C	Green	T-410-39	UP	.695
	3/8	N/R	06 'U'	T-400-3C	Green	T-410-39	UP	.695
H11408	1/2	N/R	08 'S'	T-400-4C	Black	T-410-10	DN	.860
	1/2	N/R	08 'U'	T-400-4C	Green	T-410-39	UP	.830
H11504	1/4	N/R	04 'U'	T-400-2C	Black	T-410-10	UP	.610
H11506	3/8	N/R	06 'U'	T-400-3C	Black	T-410-10	UP	.788
H11508	1/2	N/R	08 'U'	T-400-4C	Silver	T-410-11	UP	.940
H11512	3/4	N/R	12 'U'	T-400-5C	Silver	T-410-11	UP	1.232
H11516	1	N/R	16 'U'	T-400-6C	Silver	T-410-11	UP	1.522
H11520	1-1/4	N/R	20 'U'	T-400-12	Silver	T-410-11	UP	1.862
H14504	1/4	N/R	04 'M'	T-400-109C	Yellow	T-410-41	UP	.630
	1/4	N/R	04 'S'	T-400-2C	Green	T-410-39	UP	.520
	1/4	N/R	04 'U'	T-400-2C	Green	T-410-39	UP	.520
	1/4	N/R	04 'W'	T-400-40C	BK/TN	T-440-78R	UP	.678
	1/4	N/R	04 'Z'	ET400DC-M150S	Purple	ET1000SR-M100A	UP	0.612
H145R04	1/4	N/R	04 'Z'	ET400DC-M150S	Purple	ET1000SR-M100A	Up	0.612
H14506	3/8	N/R	06 'M'	T-400-110C	Yellow	T-410-41	UP	.765
	3/8	N/R	06 'S'	T-400-3C	Green	T-410-39	UP	.695
	3/8	N/R	06 'U'	T-400-3C	Green	T-410-39	UP	.695
	3/8	N/R	06 'W'	T-400-41C	Green	T-410-39	UP	.782
	3/8	N/R	06 'Z'	ET400DC-M195S	Green	T-400-39	UP	.775
H145R06	3/8	N/R	06 'Z'	ET400DC-M195S	Green	T-400-37	Up	.775
H14508	1/2	N/R	08 'M'	T-400-111C	Yellow	T-410-41	UP	.935
	1/2	N/R	08 'S'	T-400-4C	Yellow	T-410-41	DN	.870
	1/2	N/R	08 'U'	T-400-4C	Yellow	T-410-41	DN	.870
	1/2	N/R	08 'W'	T-400-42C	Black	T-410-10	DN	.976
	1/2	N/R	08 'Z'	ET400DC-M230S	Purple	ET1000SR-M100A	UP	.920
H145R08	1/2	N/R	08 'Z'	ET400DC-M230S	Purple	ET1000SR-M100A	Up	.920
H14510	5/8	N/R	10 'M'	T-410-30C	Orange	T-410-93	UP	1.085
	5/8	N/R	10 'U'	T-400-64C	Yellow	T-410-41	UP	1.010
	5/8	N/R	10 'W'	T-440-85C	N/R	N/R	N/R	1.149
	5/8	N/R	10 'Z'	T-440-85C	BK/MG	ET4000SR-M215A	UP	1.115
H145R10	5/8	N/R	10 'Z'	T-440-85C	BK/MG	ET4000SR-M215A	UP	1.115
H14512	3/4	N/R	12 'S'	T-400-5C	Yellow	T-410-41	DN	1.160
	3/4	N/R	12 'U'	T-400-5C	Yellow	T-410-41	DN	1.160
	3/4	N/R	12 'W'	T-440-86C	BK/OR	T-440-81R	UP	1.293
	3/4	N/R	12 'Z'	T-440-86C	Orange	T-410-93	UP	1.275
H145R12	3/4	N/R	12 'Z'	T-440-86C	Orange	T-410-93	UP	1.275
H14516	1	N/R	16 'S'	T-400-6C	Yellow	T-410-41	DN	1.445
	1	N/R	43016 'U'	T-410-6CN	Orange	T-410-93	UP	1.655
	1	N/R	16 'W'	T-440-87C	BK/WH	T-440-80R	UP	1.587
	1	N/R	16 'Z'	ET420DC-M380S	BK/BU	T-440-82R	UP	1.575
H145R16	1	N/R	16 'Z'	ET420DC-M380S	BK/BU	T-420-82R	UP	1.575
H14604	1/4	N/R	04 'U'	T-400-2C	Green	T-410-39	UP	.520
H14606	3/8	N/R	06 'U'	T-400-3C	Green	T-410-39	UP	.695
H14608	1/2	N/R	08 'U'	T-400-4C	Green	T-410-39	UP	.830
H16604	3/16	N/R	06904 'E'	T-400-54C	Yellow	T-410-41	UP	.525
H16605	1/4	N/R	06905 'E'	T-400-55C	Black	T-410-10	UP	.585
H16606	5/16	N/R	06906 'E'	T-400-56C	Black	T-410-10	UP	.680
H16608	13/32	N/R	06908 'E'	T-400-57C	Yellow	T-410-41	UP	.765
H16610	1/2	N/R	06910 'E'	T-400-58C	Black	T-410-10	UP	.910
H16612	5/8	N/R	06912 'E'	T-400-59C	Silver	T-410-11	UP	1.080
H16616	7/8	N/R	06916 'E'	T-400-60C	Black	T-410-10	UP	1.275
H16620	1-1/8	N/R	06920 'E'	T-400-61C	Yellow	T-410-41	UP	1.520

Note:

T-410-25 adapter die ring required when using T-400 series collets.

BK=Black **BU**=Blue **OR**=Orange
RD=Red **TN**=Tan **WH**=White
YW=Yellow **SV**=Silver **MG**=Magenta
GY=Gray **GR**=Green **BR**=Brown

Tooling Selector Chart

T-410

HOSE TYPE	HOSE I.D. (IN.)	SKIVE TOOL	HOSE END PREFIX	COLLET PART #	SPACER RING COLOR	SPACER RING PART #	FLAT SIDE UP/DN	NOMINAL CRIMP DIA. (IN.)
H16904	3/16	N/R	06904 'E'	T-400-54C	Yellow	T-410-41	UP	.525
H16905	1/4	N/R	06905 'E'	T-400-55C	Black	T-410-10	UP	.585
H16906	5/16	N/R	06906 'E'	T-400-56C	Black	T-410-10	UP	.680
H16908	13/32	N/R	06908 'E'	T-400-57C	Yellow	T-410-41	UP	.765
H16910	1/2	N/R	06910 'E'	T-400-58C	Black	T-410-10	UP	.910
H16912	5/8	N/R	06912 'E'	T-400-59C	Silver	T-410-11	UP	1.080
H16916	7/8	N/R	06916 'E'	T-400-60C	Black	T-410-10	UP	1.275
H16920	1-1/8	N/R	06920 'E'	T-400-61C	Yellow	T-410-41	UP	1.520
H16924	1-3/8	N/R	06924 'E'	T-400-70	Black	T-410-10	UP	1.730
H19004	1/4	N/R	04 'W'	T-400-40C	Black	T-410-10	DN	.664
	1/4	N/R	04 'Z'	ET400DC-M150S	Purple	ET1000SR-M100A	UP	.620
H190H04	1/4	N/R	04 'Z'	ET400DC-M150S	Purple	ET1000SR-M100A	UP	.620
H19006	3/8	N/R	06 'W'	T-400-41C	Black	T-410-10	DN	.820
	3/8	N/R	06 'Z'	ET400DC-M195S	Green	T-400-37	UP	.770
H190H06	3/8	N/R	06 'Z'	ET400DC-M195S	Green	T-400-37	UP	.770
H19008	1/2	N/R	08 'W'	T-400-42C	Black	T-410-10	DN	.976
	1/2	N/R	08 'Z'	ET400DC-M230S	Black	T-410-10	DN	.940
H190H08	1/2	N/R	08 'Z'	ET400DC-M230S	Black	T-410-10	DN	.940
H19010	5/8	N/R	10 'W'	T-440-85C	BK/WH	T-440-80R	UP	1.132
	5/8	N/R	10 'Z'	T-440-85C	Pink	T420SR-M660A	UP	1.055
H190H10	5/8	N/R	10 'Z'	T-440-85C	Pink	T420SR-M660A	UP	1.055
H19012	3/4	N/R	12 'W'	T-440-86C	BK/BU	T-440-82R	UP	1.260
	3/4	N/R	12 'Z'	T-440-86C	Brown	ET420SR-M495A	UP	1.250
H190H12	3/4	N/R	12 'Z'	T-440-86C	Brown	ET420SR-M495A	UP	1.250
H19016	1	N/R	16 'W'	T-440-87C	BK/WH	T-440-80R	UP	1.587
	1	N/R	16 'Z'	ET4000DC-M380S	Orange	T-420-28	UP	1.590
H190H16	1	N/R	16 'Z'	ET4000DC-M380S	Orange	T-420-28	UP	1.590
H19020	1-1/4	N/R	20 'Z'	ET4000DC-M420S	N/R	N/R	N/R	1.800
H190H20	1-1/4	N/R	20 'Z'	ET4000DC-M420S	N/R	N/R	N/R	1.800
H19024	1-1/2	N/R	24 'Z'	ET4000DC-M535S	N/R	N/R	N/R	2.181
H19032	2	N/R	32 'Z'	ET4000DC-M550S	N/R	N/R	N/R	2.701
H20904	1/4	N/R	04 'E'	T-400-31C	Black	T-410-10	DN	.455
H20905	5/16	N/R	05 'E'	T-400-32C	Black	T-410-10	DN	.555
H20906	3/8	N/R	06 'E'	T-400-33C	Black	T-410-10	DN	.615
H20908	1/2	N/R	08 'E'	T-400-34C	Black	T-410-10	DN	.765
H22904	3/16	N/R	06904 'E'	T-400-54C	Yellow	T-410-41	UP	.525
	3/16	N/R	22904 'P'	T-400-80C	Yellow	T-410-41	UP	.505
H22906	5/16	N/R	06906 'E'	T-400-56C	Black	T-410-10	UP	.680
	5/16	N/R	22906 'P'	T-400-81C	Black	T-410-10	DN	.650
H22908	13/32	N/R	06908 'E'	T-400-57C	Yellow	T-410-41	UP	.765
	13/32	N/R	22908 'P'	T-400-82C	Black	T-410-10	DN	.775
H22910	1/2	N/R	06910 'E'	T-400-58C	Black	T-410-10	UP	.910
	1/2	N/R	22910 'P'	T-400-83C	Black	T-410-10	DN	.875
H22912	5/8	N/R	06912 'E'	T-400-59C	Silver	T-410-11	UP	1.080
H22916	7/8	N/R	06916 'E'	T-400-60C	Black	T-410-10	UP	1.275
H23904	3/16	N/R	069 'E'	T-400-54C	Yellow	T-410-41	UP	.525
	3/16	N/R	229 'P'	T-400-80C	Black	T-410-10	DN	.480
H23906	5/16	N/R	069 'E'	T-400-56C	Black	T-410-10	UP	.680
	5/16	N/R	229 'P'	T-400-81C	Black	T-410-10	DN	.650
H23908	13/32	N/R	069 'E'	T-400-57C	Yellow	T-410-41	UP	.765
	13/32	N/R	229 'P'	T-400-82C	Black	T-410-10	DN	.775
H23910	1/2	N/R	069 'E'	T-400-58C	Black	T-410-10	UP	.910
	1/2	N/R	229 'P'	T-400-83C	Black	T-410-10	DN	.875
H23912	5/8	N/R	069 'E'	T-400-59C	Silver	T-410-11	UP	1.080
H23916	7/8	N/R	069 'E'	T-400-60C	Black	T-410-10	UP	1.275
H23920	1-1/8	N/R	069 'E'	T-400-61C	Yellow	T-410-41	UP	1.510
H24303	3/16	N/R	03 'E'	T-400-113C	Tan	T-410-42	UP	.355
H24304	1/4	N/R	04 'E'	T-400-31C	Green	T-410-39	UP	.405
H24305	5/16	N/R	05 'E'	T-400-32C	Red	T-410-40	UP	.475

Note:
T-410-25 adapter die ring required when using T-400 series collets.

BK=Black **BU**=Blue **OR**=Orange
RD=Red **TN**=Tan **WH**=White
YW=Yellow **SV**=Silver **MG**=Magenta
GY=Gray **GR**=Green **BR**=Brown

Tooling Selector Chart

T-410

HOSE TYPE	HOSE I.D. (IN.)	SKIVE TOOL	HOSE END PREFIX	COLLET PART #	SPACER RING COLOR	SPACER RING PART #	FLAT SIDE UP/DN	NOMINAL CRIMP DIA. (IN.)
H24306	3/8	N/R	06 'E'	T-400-33C	Red	T-410-40	UP	.545
H24308	1/2	N/R	08 'E'	T-400-34C	Red	T-410-40	UP	.695
H24312	3/4	N/R	12 'E'	T-400-35C	Red	T-410-40	UP	.978
H24316	1	N/R	16 'E'	T-400-36C	Red	T-410-40	UP	1.225
H24504	1/4	N/R	04 'M'	T-400-109C	Black	T-410-10	UP	.665
	1/4	N/R	04 'S'	T-400-2C	Yellow	T-410-41	DN	.560
	1/4	N/R	04 'U'	T-400-2C	Yellow	T-410-41	DN	.560
	1/4	N/R	04 'W'	T-400-40C	BK/TN	T-440-78R	UP	.678
	1/4	N/R	04 'Z'	ET400DC-M150S	BK/TN	T-440-78R	UP	.650
H245L04	1/4	N/R	04 'Z'	ET400DC-M150S	Black	T-410-10	DN	0.640
H24506	3/8	N/R	06 'M'	T-400-110C	Black	T-410-10	UP	.805
	3/8	N/R	06 'S'	T-400-3C	Yellow	T-410-41	DN	.740
	3/8	N/R	06 'U'	T-400-3C	Yellow	T-410-41	DN	.740
	3/8	N/R	06 'W'	T-400-41C	Black	T-410-10	DN	.820
	3/8	N/R	06 'Z'	ET400DC-M195S	Black	T-410-10	DN	.815
H245L06	3/8	N/R	06 'Z'	ET400DC-M195S	Tan	T-400-112	UP	.800
H24508	1/2	N/R	08 'M'	T-400-111C	Yellow	T-410-41	UP	.940
	1/2	N/R	08 'S'	T-400-4C	Yellow	T-410-41	DN	.865
	1/2	N/R	08 'U'	T-400-4C	Yellow	T-410-41	DN	.865
	1/2	N/R	08 'W'	T-400-42C	BK/TN	T-440-78R	UP	.993
	1/2	N/R	08 'Z'	ET400DC-M230S	Lt. Green	ET4000SR-M190D	UP	.975
H245L08	1/2	N/R	08 'Z'	ET400DC-M230S	Lt. Green	ET4000SR-M190D	UP	.975
H24510	5/8	N/R	10 'U'	T-400-64C	Yellow	T-410-41	UP	1.010
	5/8	N/R	10 'M'	T-410-30C	Orange	T-410-93	UP	1.085
	5/8	N/R	10 'W'	T-440-85C	BK/WH	T-440-80R	UP	1.132
	5/8	N/R	10 'Z'	T-440-85C	BK/MG	ET4000SR-M215A	UP	1.115
H245L10	5/8	N/R	10 'Z'	T-440-85C	BK/MG	ET4000SR-M215A	UP	1.115
H24512	3/4	N/R	12 'U'	T-400-5C	Yellow	T-410-41	DN	1.160
	3/4	N/R	43012 'U'	T-410-5CN	Orange	T-410-93	UP	1.365
	3/4	N/R	12 'W'	T-440-86C	BK/OR	T-440-81R	UP	1.293
	3/4	N/R	12 'S'	T-400-5C	Yellow	T-410-41	DN	1.160
	3/4	N/R	12 'Z'	T-440-86C	Brown	ET4000SR-M405A	UP	1.245
H245L12	3/4	N/R	12 'Z'	T-440-86C	Brown	ET420SR-M495A	UP	1.245
H24516	1	N/R	16 'S'	T-400-6C	Yellow	T-410-41	UP	1.465
	1	N/R	16 'U'	T-400-6C	Yellow	T-410-41	UP	1.465
	1	N/R	43016 'U'	T-410-6CN	Orange	T-410-93	UP	1.660
	1	N/R	16 'W'	T-440-87C	BK/WH	T-440-80R	UP	1.587
	1	N/R	16 'Z'	ET4000DC-M380S	Brown	ET4000SR-M405A	UP	1.565
H245L16	1	N/R	16 'Z'	ET4000DC-M380S	Brown	ET420SR-M495A	UP	1.565
H24520	1-1/4	N/R	20 'S'	T-400-12	Yellow	T-410-41	DN	1.795
	1-1/4	N/R	20 'U'	T-400-12	Yellow	T-410-41	DN	1.795
	1-1/4	N/R	43020 'U'	T-410-7CN	Orange	T-410-93	UP	1.990
	1-1/4	N/R	20 'Z'	ET4000DC-M480S	BK/BR	ET4000SR-M345A	UP	1.900
H245L20	1-1/4	N/R	20 'Z'	ET4000DC-M480S	BK/BR	ET4000SR-M345A	UP	1.900
H245L24	1-1/2	N/R	24 'Z'	ET4000DC-M530S	N/R	N/R	N/R	2.155
H245L32	2	N/R	32 'Z'	ET4000DC-M550S	N/R	N/R	N/R	2.700
H26504	1/4	N/R	26504 'P'	T-400-2C	Green	T-410-39	UP	.520
H26506	3/8	N/R	06 'E'	T-400-33C	Black	T-410-10	UP	.660
	3/8	N/R	26506 'P'	T-400-2C	Silver	T-410-11	UP	.640
H26508	1/2	N/R	08 'E'	T-400-34C	Black	T-410-10	UP	.810
	1/2	N/R	26508 'P'	T-400-3C	Black	T-410-10	UP	.788
H26512	3/4	N/R	12 'E'	T-400-35C	Black	T-410-10	UP	1.090
	3/4	N/R	26512 'P'	T-400-64C	Silver	T-410-11	UP	1.070
H26516	1	N/R	16 'E'	T-400-36C	Black	T-410-10	UP	1.340
H27504	1/4	N/R	26504 'P'	T-400-2C	Green	T-410-39	UP	.520
H27506	3/8	N/R	06 'E'	T-400-33C	Black	T-410-10	UP	.660
	3/8	N/R	26506 'P'	T-400-2C	Silver	T-410-11	UP	.640
H27508	1/2	N/R	08 'E'	T-400-34C	Black	T-410-10	UP	.810
	1/2	N/R	26508 'P'	T-400-3C	Black	T-410-10	UP	.788

Note:
T-410-25 adapter die ring required when using T-400 series collets.

BK=Black **BU**=Blue **OR**=Orange
RD=Red **TN**=Tan **WH**=White
YW=Yellow **SV**=Silver **MG**=Magenta
GY=Gray **GR**=Green **BR**=Brown

Tooling Selector Chart

T-410

HOSE TYPE	HOSE I.D. (IN.)	SKIVE TOOL	HOSE END PREFIX	COLLET PART #	SPACER RING COLOR	SPACER RING PART #	FLAT SIDE UP/DN	NOMINAL CRIMP DIA. (IN.)
H27512	3/4	N/R	12 'E'	T-400-35C	Black	T-410-10	UP	1.090
	3/4	N/R	26512 'P'	T-400-64C	Silver	T-410-11	UP	1.070
H27516	1	N/R	16 'E'	T-400-36C	Black	T-410-10	UP	1.340
H27703	3/16	N/R	03 'E'	T-400-113C	Tan	T-410-42	UP	.355
H27704	1/4	N/R	04 'E'	T-400-31C	Green	T-410-39	UP	.405
H27705	5/16	N/R	05 'E'	T-400-32C	Red	T-410-40	UP	.475
H27706	3/8	N/R	06 'E'	T-400-33C	Red	T-410-40	UP	.545
H27708	1/2	N/R	08 'E'	T-400-34C	Red	T-410-40	UP	.695
H27712	3/4	N/R	12 'E'	T-400-35C	Red	T-410-40	UP	.978
H27716	1	N/R	16 'E'	T-400-36C	Red	T-410-40	UP	1.225
H28004	1/4	N/R	04 'W'	T-400-40C	BK/TN	T-440-78R	UP	.678
	1/4	N/R	04 'Z'	ET400DC-M150S	Yellow	T-410-41	UP	.665
H28006	3/8	N/R	06 'W'	T-400-41C	Black	T-410-10	DN	.820
	3/8	N/R	06 'Z'	ET400DC-M195S	Black	T-410-10	DN	.815
H28008	1/2	N/R	08 'W'	T-400-42C	BK/TN	T-440-78R	UP	.992
	1/2	N/R	08 'Z'	ET400DC-M230S	Lt. Green	ET4000SR-M190D	UP	.975
H28010	5/8	N/R	10 'W'	T-440-85C	BK/WH	T-440-80R	UP	1.132
	5/8	N/R	10 'Z'	T-440-85C	BK/MG	ET4000SR-M215A	UP	1.115
H28012	3/4	N/R	12 'W'	T-440-86C	BK/OR	T-440-81R	UP	1.293
	3/4	N/R	12 'Z'	T-440-86C	Brown	ET4000SR-M405A	UP	1.245
H28016	1	N/R	16 'W'	T-440-87C	BK/WH	T-440-80R	UP	1.587
	1	N/R	16 'Z'	ET4000DC-M380S	Brown	ET4000SR-M405A	UP	1.565
H28020	1-1/4	N/R	20 'Z'	ET4000DC-M480S	BK/BR	ET4000SR-M345A	UP	1.900
H28024	1-1/2	N/R	24 'Z'	ET4000DC-M530S	N/R	N/R	N/R	2.151
H28032	2	N/R	32 'Z'	ET4000DC-M550S	N/R	N/R	N/R	2.7
H28504	1/4	N/R	04 'E'	T-400-31C	Black	T-410-10	UP	.500
H28504	1/4	N/R	26504 'P'	T-400-2C	Green	T-410-39	UP	.520
H28506	3/8	N/R	06 'E'	T-400-33C	Black	T-410-10	UP	.660
	3/8	N/R	26506 'P'	T-400-2C	Silver	T-410-11	UP	.640
H28508	1/2	N/R	08 'E'	T-400-34C	Black	T-410-10	UP	.810
	1/2	N/R	26508 'P'	T-400-3C	Black	T-410-10	UP	.788
H28512	3/4	N/R	12 'E'	T-400-35C	Black	T-410-10	UP	1.090
	3/4	N/R	26512 'P'	T-400-64C	Silver	T-410-11	UP	1.070
H28516	1	N/R	16 'E'	T-400-36C	Black	T-410-10	UP	1.340
H29004	1/4	N/R	04 'W'	T-400-40C	Black	T-410-10	UP	.722
	1/4	N/R	04 'Z'	ET400DC-M150S	Lt. Green	ET4000SR-M190D	UP	.680
H290H04	1/4	N/R	04 'Z'	ET400DC-M150S	Lt Green	ET4000SR-M190D	UP	.680
H29006	3/8	N/R	06 'W'	T-400-41C	BK/RD	T-440-79R	UP	.854
	3/8	N/R	06 'Z'	ET400DC-M195S	Yellow	T-410-41	UP	.835
H290H06	3/8	N/R	06 'Z'	ET400DC-M195S	Yellow	T-410-41	UP	.835
H29008	1/2	N/R	08 'W'	T-400-42C	BK/RD	T-440-79R	UP	1.007
	1/2	N/R	08 'Z'	ET400DC-M230S	Black	T-410-10	UP	.990
H290H08	1/2	N/R	08 'Z'	ET400DC-M230S	Black	T-410-10	UP	.990
H29010	5/8	N/R	10 'W'	T-440-85C	N/R	N/R	N/R	1.149
	5/8	N/R	10 'Z'	T-440-85C	BK/WH	T-440-80R	UP	1.130
H290H10	5/8	N/R	10 'Z'	T-440-85C	BK/WH	T-440-80R	UP	1.130
H29012	3/4	N/R	12 'W'	T-440-86C	N/R	N/R	N/R	1.317
	3/4	N/R	12 'Z'	T-440-86C	BK/MG	ET4000SR-M215A	UP	1.280
H290H12	3/4	N/R	12 'Z'	T-440-86C	BK/MG	ET4000SR-M215A	UP	1.280
H29016	1	N/R	16 'W'	T-440-87C	N/R	N/R	N/R	1.607
	1	N/R	16 'Z'	ET4000DC-M380S	N/A	N/A	N/A	1.640
H290H16	1	N/R	16 'Z'	ET4000DC-M380S	N/R	N/R	N/R	1.640
H29020	1-1/4	N/R	20 'Z'	T-410-7CN	BK/PU	ET4000SR-M180A	UP	2.000
	1-1/4	N/R	20 'Z'	ET4000DC-M480S	N/R	N/R	N/R	1.960
H290H20	1-1/4	N/R	20 'Z'	T-410-7CN	BK/PU	ET4000SR-M180A	UP	2.000
H29024	1-1/2	N/R	24 'Z'	ET4000DC-M560S	Purple	ET4000SR-M180A	UP	2.270
	1-1/2	N/R	24 'Z'	ET4000DC-M560S	Purple	ET4000SR-M180S	UP	2.270
H290H24	1-1/2	N/R	24 'Z'	ET4000DC-M560S	Purple	ET4000SR-M180A	UP	2.270
H29032	2	N/R	32 'Z'	ET4000DC-M570S	N/R	N/R	N/R	2.770

Note:
T-410-25 adapter die ring required when using T-400 series collets.

BK=Black **BU**=Blue **OR**=Orange
RD=Red **TN**=Tan **WH**=White
YW=Yellow **SV**=Silver **MG**=Magenta
GY=Gray **GR**=Green **BR**=Brown

Tooling Selector Chart

T-410

HOSE TYPE	HOSE I.D. (IN.)	SKIVE TOOL	HOSE END PREFIX	COLLET PART #	SPACER RING COLOR	SPACER RING PART #	FLAT SIDE UP/DN	NOMINAL CRIMP DIA. (IN.)
	2	N/R	32 'Z'	ET4000DC-M580S	N/R	N/R	N/R	2.790
H290H32	2	N/R	32 'Z'	ET4000DC-M570S	N/R	N/R	N/R	2.770
H32406	3/8	N/R	06 'U'	T-400-3C	Black	T-410-10	UP	.785
H32504	1/4	N/R	04 'U'	T-400-2C	Black	T-410-10	UP	.610
H32506	3/8	N/R	06 'U'	T-400-3C	Black	T-410-10	UP	.795
H32508	1/2	N/R	08 'U'	T-400-4C	Yellow	T-410-41	UP	.885
H32512	3/4	N/R	12 'U'	T-400-5C	Black	T-410-10	UP	1.215
H32516	1	N/R	16 'U'	T-400-6C	Silver	T-410-11	UP	1.525
H33503	3/16	N/R	33603 'E'	T-400-120C	Black	T-410-10	UP	.540
H33504	1/4	N/R	33604 'E'	T-400-121C	Black	T-410-10	UP	.667
H33506	3/8	N/R	33606 'E'	T-400-122C	Black	T-410-10	UP	.770
H33508	1/2	N/R	33608 'E'	T-400-123C	Black	T-410-10	UP	.895
H33603	3/16	N/R	33603 'E'	T-400-120C	Black	T-410-10	UP	.540
H33604	1/4	N/R	33604 'E'	T-400-121C	Black	T-410-10	UP	.667
H33606	3/8	N/R	33606 'E'	T-400-122C	Black	T-410-10	UP	.770
H33608	1/2	N/R	33608 'E'	T-400-123C	Black	T-410-10	UP	.895
H33806	3/8	N/R	33806 'P'	T-400-102C	Black	T-410-10	DN	.700
H33808	1/2	N/R	33808 'P'	T-400-103C	Black	T-410-10	DN	.795
H34504	1/4	N/R	04 'M'	T-400-109C	Yellow	T-410-41	UP	.630
	1/4	N/R	04 'W'	T-400-40C	Black	T-410-10	DN	.664
	1/4	N/R	04 'Z'	ET400DC-M150S	Tan	T-410-42	UP	0.625
H34506	3/8	N/R	06 'M'	T-400-110C	Yellow	T-410-41	UP	.765
	3/8	N/R	06 'W'	T-400-41C	Green	T-410-39	UP	.782
	3/8	N/R	06 'Z'	ET400DC-M195S	Green	T-410-39	UP	0.775
H34508	1/2	N/R	08 'M'	T-400-111C	Yellow	T-410-41	DN	.915
	1/2	N/R	08 'W'	T-400-42C	Black	T-410-10	DN	.976
	1/2	N/R	08 'Z'	ET400DC-M230S	Black	T-410-10	DN	0.940
H35006	3/8	N/R	06 'M'	T-400-110C	Black	T-410-10	UP	.805
	3/8	N/R	06 'W'	T-400-41C	Black	T-410-10	DN	.820
	3/8	N/R	06 'U'	T-400-3C	Yellow	T-410-41	DN	.740
	3/8	N/R	06 'Z'	ET400DC-M195S	Black	T-410-10	DN	.815
H35008	1/2	N/R	08 'M'	T-400-111C	Yellow	T-410-41	UP	.945
	1/2	N/R	08 'W'	T-400-42C	BK/TN	T-440-78R	UP	.993
	1/2	N/R	08 'U'	T-400-4C	Yellow	T-410-41	DN	.865
	1/2	N/R	08 'Z'	ET400DC-M230S	Lt. Green	ET4000SR-M190D	UP	.975
H35010	5/8	N/R	10 'M'	T-410-30C	N/R	N/R	N/R	1.120
H35010	5/8	N/R	10 'W'	T-440-85C	BK/WH	T-440-80R	N/R	1.132
	5/8	N/R	10 'Z'	T-440-85C	BK/WH	T-440-80R	UP	1.130
H35012	3/4	N/R	43012 'U'	T-410-5CN	N/R	N/R	N/R	1.413
H35016	1	N/R	43016 'U'	T-410-6CN	N/R	N/R	N/R	1.705
H36606	5/16	N/R	06906 'E'	T-400-56C	Black	T-410-10	UP	.680
H36608	13/32	N/R	06908 'E'	T-400-57C	Yellow	T-410-41	UP	.765
H40006	1/4	N/R	04 'Z'	ET400DC-M195S	Yellow	T-400-62	UP	.835
H40008	3/8	N/R	06 'Z'	ET400DC-M230S	Black	T-400-10	UP	.990
H40010	5/8	N/R	10 'M'	T-410-30C	N/R	N/R	N/R	1.120
	5/8	N/R	10 'W'	T-440-85C	N/R	N/R	N/R	1.149
	5/8	N/R	10 'Z'	T-440-85C	BK/WH	T-440-80R	UP	1.129
H40012	3/4	N/R	12 'W'	T-440-86C	N/R	N/R	N/R	1.317
	3/4	N/R	12 'Z'	T-440-86C	BK/MG	ET4000SR-M255A	UP	1.286
H42104	1/4	N/R	04 'Z'	ET400DC-M150S	BK/RD	T-400-47R	UP	.665
H42106	3/8	N/R	06 'Z'	ET400DC-M195S	Yellow	T-400-62	UP	.835
H42504	1/4	N/R	04 'S'	T-400-2C	Black	T-410-10	UP	.610
H42504	1/4	N/R	04 'U'	T-400-2C	Black	T-410-10	UP	.610
	1/4	N/R	04 'W'	T-400-40C	Black	T-410-10	UP	.722
	1/4	N/R	04 'Z'	ET400DC-M150S	Yellow	T-410-41	UP	.665
H42506	3/8	N/R	06 'S'	T-400-3C	Black	T-410-10	UP	.795
	3/8	N/R	06 'U'	T-400-3C	Black	T-410-10	UP	.795
	3/8	N/R	06 'W'	T-400-41C	BK/RD	T-440-79R	UP	.854
	3/8	N/R	06 'Z'	ET400DC-M195S	Yellow	T-410-41	UP	.835

Note:

T-410-25 adapter die ring required when using T-400 series collets.

BK=Black **BU**=Blue **OR**=Orange
RD=Red **TN**=Tan **WH**=White
YW=Yellow **SV**=Silver **MG**=Magenta
GY=Gray **GR**=Green **BR**=Brown

Tooling Selector Chart

T-410

HOSE TYPE	HOSE I.D. (IN.)	SKIVE TOOL	HOSE END PREFIX	COLLET PART #	SPACER RING COLOR	SPACER RING PART #	FLAT SIDE UP/DN	NOMINAL CRIMP DIA. (IN.)
H42508	1/2	N/R	08 'S'	T-400-4C	Black	T-410-10	UP	.920
	1/2	N/R	08 'U'	T-400-4C	Black	T-410-10	UP	.915
	1/2	N/R	08 'W'	T-400-42C	BK/RD	T-440-79R	UP	1.007
	1/2	N/R	08 'Z'	ET400DC-M230S	Black	T-410-10	UP	.990
H42510	5/8	N/R	10 'U'	T-400-64C	Black	T-410-10	UP	1.050
	5/8	N/R	10 'W'	T-440-85C	BK/WH	T-440-80R	UP	1.132
	5/8	N/R	10 'Z'	T-440-85C	BK/WH	T-440-80R	UP	1.130
H42512	3/4	N/R	12 'S'	T-400-5C	Black	T-410-10	UP	1.210
	3/4	N/R	12 'U'	T-400-5C	Black	T-410-10	UP	1.205
	3/4	N/R	43012 'U'	T-410-5CN	N/R	N/R	N/R	1.410
	3/4	N/R	12 'W'	T-440-86C	N/R	N/R	N/R	1.317
	3/4	N/R	12 'Z'	T-440-86C	BK/MG	ET4000SR-M215A	UP	1.280
H42516	1	N/R	16 'S'	T-400-6C	Silver	T-410-11	UP	1.525
	1	N/R	16 'U'	T-400-6C	Silver	T-410-11	UP	1.525
	1	N/R	43016 'U'	T-410-6CN	N/R	N/R	N/R	1.707
	1	N/R	16 'W'	T-440-87C	N/R	N/R	N/R	1.607
	1	N/R	16 'Z'	ET4000DC-M380S	N/A	N/A	N/A	1.630
H42520	1-1/4	N/R	20 'S'	T-400-12	Silver	T-410-11	UP	1.885
	1-1/4	N/R	20 'U'	T-400-12	Black	T-410-10	UP	1.850
	1-1/4	N/R	43020 'U'	T-410-7CN	N/R	N/R	N/R	2.035
	1-1/4	N/R	20 'Z'	ET4000DC-M480S	N/A	N/A	N/A	1.960
H42524	1-1/2	N/R	43024 'U'	T-410-8N	N/R	N/R	N/R	2.270
H42532	2	N/R	43032 'U'	T-410-9N	N/R	N/R	N/R	2.890
H42908	13/32	N/R	057 'P'	T-400-102C	Green	T-410-39	UP	.660
H42910	1/2	N/R	057 'P'	T-400-103C	Green	T-410-39	UP	.750
H43008	1/2	N/R	43008 'U'	T-410-4CN	N/R	N/R	N/R	1.150
H430R08	1/2	N/R	430U	T-420-4CN	N/R	N/R	N/R	1.150
H43012	3/4	N/R	43012 'U'	T-410-5CN	N/R	N/R	N/R	1.406
H430R12	3/4	N/R	430U	T-420-5CN	N/R	N/R	N/R	1.406
H43016	1	N/R	43016 'U'	T-410-6CN	N/R	N/R	N/R	1.705
H430R16	1	N/R	430U	T-420-6CN	N/R	N/R	N/R	1.705
H43020	1-1/4	N/R	43020 'U'	T-410-7CN	N/R	N/R	N/R	2.035
H430R20	1-1/4	N/R	430U	T-420-7CN	N/R	N/R	N/R	2.035
H43024	1-1/2	N/R	43024 'U'	T-410-8N	N/R	N/R	N/R	2.285
H430R24	1-1/2	N/R	430U	T-410-8CN	N/R	N/R	N/R	2.285
H43032	2	N/R	43032 'U'	T-410-9N	N/R	N/R	N/R	2.895
H430R32	2	N/R	430U	T-410-9CN	N/R	N/R	N/R	2.895
H43504	1/4	N/R	04 'E'	T-400-31C	Black	T-410-10	DN	.455
H43505	5/16	N/R	05 'E'	T-400-32C	Black	T-410-10	DN	.555
H43506	3/8	N/R	06 'E'	T-400-33C	Black	T-410-10	DN	.615
H43508	1/2	N/R	08 'E'	T-400-34C	Black	T-410-10	DN	.765
H43512	3/4	N/R	12 'E'	T-400-35C	Black	T-410-10	DN	1.035
H43516	1	N/R	16 'E'	T-400-36C	Black	T-410-10	DN	1.295
H43604	1/4	N/R	04 'E'	T-400-31C	Black	T-410-10	DN	.455
H43605	5/16	N/R	05 'E'	T-400-32C	Black	T-410-10	DN	.555
H43606	3/8	N/R	06 'E'	T-400-33C	Black	T-410-10	DN	.615
H43608	1/2	N/R	08 'E'	T-400-34C	Black	T-410-10	DN	.765
H43612	3/4	N/R	12 'E'	T-400-35C	Black	T-410-10	DN	1.035
H43616	1	N/R	16 'E'	T-400-36C	Black	T-410-10	DN	1.295
H47008	1/2		T-410-50 47008 'E'	T-470-8C	N/R	N/R	N/R	.980
H47012	3/4		T-410-52 47012 'E'	T-470-12C	N/R	N/R	N/R	1.250
	3/4		T-410-52 57012 'S'	T-470-12C	N/R	N/R	N/R	1.250
H47016	1		T-410-53 47016 'E'	T-470-16C	N/R	N/R	N/R	1.560
	1		T-410-53 57016 'S'	T-470-16C	N/R	N/R	N/R	1.560
H47020	1-1/4		T-410-54 47020 'E'	T-470-20	N/R	N/R	N/R	2.025
	1-1/4		T-410-54 57020 'S'	T-470-20	N/R	N/R	N/R	2.025
H47024	1-1/2		T-410-55 47024 'E'	T-470-24	N/R	N/R	N/R	2.365
	1-1/2		T-410-55 57024 'S'	T-470-24	N/R	N/R	N/R	2.365

Note:
T-410-25 adapter die ring required when using T-400 series collets.

BK=Black **BU**=Blue **OR**=Orange
RD=Red **TN**=Tan **WH**=White
YW=Yellow **SV**=Silver **MG**=Magenta
GY=Gray **GR**=Green **BR**=Brown

Tooling Selector Chart

T-410

HOSE TYPE	HOSE I.D. (IN.)	SKIVE TOOL	HOSE END PREFIX	COLLET PART #	SPACER RING COLOR	SPACER RING PART #	FLAT SIDE UP/DN	NOMINAL CRIMP DIA. (IN.)
H54504	1/4	N/R	04 'S'	T-400-2C	Yellow	T-410-41	DN	.560
	1/4	N/R	04 'U'	T-400-2C	Yellow	T-410-41	DN	.560
	1/4	N/R	04 'W'	T-400-40C	Black	T-410-10	DN	.664
H54506	3/8	N/R	06 'S'	T-400-3C	Green	T-410-39	UP	.695
	3/8	N/R	06 'U'	T-400-3C	Green	T-410-39	UP	.695
	3/8	N/R	06 'W'	T-400-41C	Black	T-410-10	DN	.820
H54508	1/2	N/R	08 'S'	T-400-4C	Black	T-410-10	DN	.865
	1/2	N/R	08 'U'	T-400-4C	Yellow	T-410-41	DN	.865
	1/2	N/R	08 'W'	T-400-42C	BK/TN	T-440-78R	UP	.992
H54510	5/8	N/R	10 'U'	T-400-64C	Yellow	T-410-41	UP	1.010
	5/8	N/R	10 'W'	T-440-85C	BK/WH	T-440-80R	UP	1.132
H54512	3/4	N/R	12 'S'	T-400-5C	Yellow	T-410-41	DN	1.155
	3/4	N/R	12 'U'	T-400-5C	Yellow	T-410-41	DN	1.155
	3/4	N/R	12 'W'	T-440-86C	BK/OR	T-440-81R	UP	1.293
H54516	1	N/R	43016 'U'	T-410-6CN	N/R	N/R	N/R	1.705
	1	N/R	16 'W'	T-440-87C	BK/WH	T-440-80R	UP	1.587
H56904	3/16	N/R	06904 'E'	T-400-54C	Yellow	T-410-41	UP	.525
H56905	1/4	N/R	06905 'E'	T-400-55C	Black	T-410-10	UP	.585
H56906	5/16	N/R	06906 'E'	T-400-56C	Black	T-410-10	UP	.680
H56908	13/32	N/R	06908 'E'	T-400-57C	Yellow	T-410-41	UP	.765
H56910	1/2	N/R	06910 'E'	T-400-58C	Black	T-410-10	UP	.910
H56912	5/8	N/R	06912 'E'	T-400-59C	Silver	T-410-11	UP	1.080
H56916	7/8	N/R	06916 'E'	T-400-60C	Black	T-410-10	UP	1.275
H56920	1-1/8	N/R	06920 'E'	T-400-61C	Black	T-410-10	DN	1.485
H75706	5/16	N/R	75706 'E'	T-400-105C	Black	T-410-10	DN	.495
H75708	13/32	N/R	75708 'E'	T-400-106C	Black	T-410-10	DN	.595
H75710	1/2	N/R	75710 'E'	T-400-107C	Black	T-410-10	DN	.695
H75712	5/8	N/R	75712 'E'	T-400-108C	Black	T-410-10	DN	.850
H9610-6	3/8	N/R	06 'Z'	ET400DC-M195S	Purple	ET4000SR-M100A	UP	0.785
H9610-8	1/2	N/R	08 'Z'	ET400DC-M230S	Black	T-410-10	DN	0.940

Note:

T-410-25 adapter die ring required when using T-400 series collets.

BK=Black **BU**=Blue **OR**=Orange
RD=Red **TN**=Tan **WH**=White
YW=Yellow **SV**=Silver **MG**=Magenta
GY=Gray **GR**=Green **BR**=Brown

Tooling Selector Chart

T-440 & ET4000

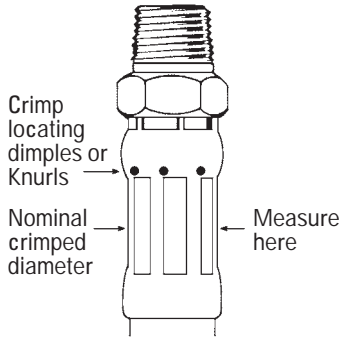
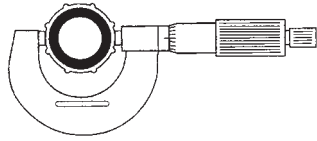

Note:
In larger sizes, calipers may be used; however, in smaller sizes, and in the 'E' Series thermoplastic hose ends, a point micrometer will provide an accurate reading. Nominal crimp diameters are for Weatherhead hose and end fittings when crimped with Weatherhead Coll-O-Crimp tooling.

Note:
T-410-10 adapter die ring required when using T-400 series collets.

⚠ WARNING

Proper Selection of Hose Ends: Selection of the proper end fittings for the hose end application is essential to the proper operation and safe use of the hose and related equipment. Inadequate attention to the selection of the end fittings for your application can result in leaking or the hose ends blowing off the hose, leading to serious bodily injury or property damage. In order to avoid serious bodily injury or property damage resulting from selection of the wrong end fitting, you should carefully review the information in the Weatherhead Catalog W-HYOV-MC002-E.

⚠ WARNING

Coll-O-Crimp Hose, Hose Fittings and Assembly Equipment Compatibility: The Coll-O-Crimp Equipment

Package, Coll-O-Crimp End Fittings, and Coll-O-Crimp Hose have been engineered and designed as a complete hose assembly system. Each component of the Coll-O-Crimp hose assembly system is compatible with other Coll-O-Crimp components to which it relates. Component compatibility, along with the use of quality components, insures the production of reliable hose assemblies when assembled properly. The use or intermixing of fittings and hose not specifically engineered and designed for use with each other and Coll-O-Crimp equipment is not recommended and may result in the production of unsafe or unreliable hose assemblies. This can result in hose assembly leakage, hose separation or other failures which can cause serious bodily injury or property damage from spraying

fluids, flying projectiles, or other substances. Eaton's Weatherhead warranty is limited to apply only when Coll-O-Crimp end fittings and compatible Coll-O-Crimp hose are used with Coll-O-Crimp assembly equipment. **Nominal Crimp Diameter Measurement:** Please remove this chart and place near your Coll-O-Crimp equipment for reference. Measuring crimp diameters should be a part of the normal hose assembly procedure. To insure a proper crimp diameter reading, follow these steps.

1. Measure the diameter in the middle of crimped portion of the hose end.
2. Place the caliper in a position to allow a measurement across the pressed (flat) portion of the crimp.
3. See crimp diameters on following chart.

T-440 & ET4000

HOSE TYPE	HOSE I.D. (IN.)	SKIVE TOOL	HOSE END PREFIX	COLLET PART #	SPACER RING COLOR	SPACER RING PART #	FLAT SIDE UP/DN	NOMINAL CRIMP DIA. (IN.)
H00905	5/16	N/R	05 'E'	T-400-32C	Black	T-410-10	UP	.585
H00906	3/8	N/R	06 'E'	T-400-33C	Black	T-410-10	UP	.655
H00908	1/2	N/R	08 'E'	T-400-34C	Black	T-410-10	UP	.805
H01704	1/4	N/R	04 'U'	T-400-2C	Yellow	T-410-41	UP	.580
H01706	3/8	N/R	06 'U'	T-400-3C	Black	T-410-10	UP	.785
H01708	1/2	N/R	08 'U'	T-400-4C	Silver	T-410-11	UP	.940
H01712	3/4	N/R	12 'U'	T-400-5C	Silver	T-410-11	UP	1.235
H01716	1	N/R	16 'U'	T-400-6C	Silver	T-410-11	UP	1.525
H01720	1-1/4	N/R	20 'U'	T-400-12	Black	T-410-10	DN	1.785
H03912	3/4	N/R	12 'S'	T-400-5C	Silver	T-410-11	UP	1.230
	3/4	N/R	12 'U'	T-400-5C	Silver	T-410-11	UP	1.230
	3/4	N/R	12 'Z'	T-410-5CN	Tan	T-410-42	UP	1.401
H039H12	3/4	N/R	12 'Z'	T-410-5CN	Tan	T-410-42	UP	1.401
H03916	1	N/R	16 'S'	T-400-6C	Silver	T-410-11	UP	1.520
	1	N/R	16 'U'	T-400-6C	Silver	T-410-11	UP	1.520
	1	N/R	16 'Z'	T-410-6CN	N/R	N/R	N/R	1.708
H039H16	1	N/R	16 'Z'	T-410-6CN	N/R	N/R	N/R	1.708
H03920	1-1/4	N/R	20 'S'	T-400-12	Black	T-410-10	DN	1.790
	1-1/4	N/R	20 'U'	T-400-12	Black	T-410-10	DN	1.790

Note:
T-410-25 adapter die ring required when using T-400 series collets.

BK=Black **BU**=Blue **OR**=Orange
RD=Red **TN**=Tan **WH**=White
YW=Yellow **SV**=Silver **MG**=Magenta
GY=Gray **GR**=Green **BR**=Brown

Tooling Selector Chart

T-440 & ET4000

HOSE TYPE	HOSE I.D. (IN.)	SKIVE TOOL	HOSE END PREFIX	COLLET PART #	SPACER RING COLOR	SPACER RING PART #	FLAT SIDE UP/DN	NOMINAL CRIMP DIA. (IN.)
	1-1/4	N/R	20 'Z'	T-400-7CN	N/R	N/R	N/R	2.026
H039H20	1-1/4	N/R	20 'Z'	T-410-7CN	N/R	N/R	N/R	2.026
H03924	1-1/2	N/R	43024 'U'	T-410-8N	N/R	N/R	N/R	2.285
	1-1/2	N/R	24 'Z'	ET4000-M560S	N/R	N/R	N/R	2.291
H039H24	1 1/2	N/R	24 'Z'	ET4000DC-M560S	N/R	N/R	N/R	2.291
H03932	2	N/R	43032 'U'	T-410-9N	N/R	N/R	N/R	2.895
	2	N/R	32 'Z'	ET4000-M570S	N/R	N/R	N/R	2.768
H039H32	2	N/R	32 'Z'	ET4000DC-M570S	N/R	N/R	N/R	2.768
H05904	3/16	N/R	06904 'E'	T-400-54C	Yellow	T-410-41	UP	.525
H05904	3/16	N/R	22904 'P'	T-400-80C	Black	T-410-10	DN	.480
H05905	1/4	N/R	06905 'E'	T-400-55C	Black	T-410-10	UP	.585
H05906	5/16	N/R	06906 'E'	T-400-56C	Black	T-410-10	UP	.680
	5/16	N/R	22906 'P'	T-400-81C	Black	T-410-10	DN	.650
H05908	13/32	N/R	06908 'E'	T-400-57C	Yellow	T-410-41	UP	.765
H05908	13/32	N/R	22908 'P'	T-400-82C	Black	T-410-10	DN	.775
H05910	1/2	N/R	06910 'E'	T-400-58C	Black	T-410-10	UP	.910
	1/2	N/R	22910 'P'	T-400-83C	Black	T-410-10	DN	.875
H05912	5/8	N/R	06912 'E'	T-400-59C	Silver	T-410-11	UP	1.080
H05916	7/8	N/R	06916 'E'	T-400-60C	Black	T-410-10	UP	1.275
H06904	3/16	N/R	06904 'E'	T-400-54C	Yellow	T-410-41	UP	.525
H06905	1/4	N/R	06905 'E'	T-400-55C	Black	T-410-10	UP	.585
H06906	5/16	N/R	06906 'E'	T-400-56C	Black	T-410-10	UP	.680
H06908	13/32	N/R	06908 'E'	T-400-57C	Yellow	T-410-41	UP	.765
H06910	1/2	N/R	06910 'E'	T-400-58C	Black	T-410-10	UP	.910
H06912	5/8	N/R	06912 'E'	T-400-59C	Silver	T-410-11	UP	1.080
H06916	7/8	N/R	06916 'E'	T-400-60C	Black	T-410-10	UP	1.275
H06920	1-1/8	N/R	06920 'E'	T-400-61C	Yellow	T-410-41	UP	1.520
H06924	1-3/8	N/R	06924 'E'	T-400-70	Black	T-410-10	UP	1.730
H06932	1-13/16	N/R	06932 'E'	T-410-71C	N/R	N/R	N/R	2.202
H10404	1/4	N/R	04 'S'	T-400-2C	Black	T-410-10	DN	.561
	1/4	N/R	04 'U'	T-400-2C	Black	T-410-10	DN	.560
	1/4	N/R	04 'W'	T-400-40C	Black	T-410-10	DN	.664
	1/4	N/R	04 'Z'	ET400DC-M150S	Purple	ET4000SR-M100A	UP	0.620
H10406	3/8	N/R	06 'S'	T-400-3C	Black	T-410-10	DN	.740
	3/8	N/R	06 'U'	T-400-3C	Black	T-410-10	DN	.740
	3/8	N/R	06 'W'	T-400-41C	Black	T-410-10	DN	.820
	3/8	N/R	06 'Z'	ET400DC-M195S	Purple	ET4000SR-M100A	UP	0.785
H10408	1/2	N/R	08 'S'	T-400-4C	Black	T-410-10	DN	.863
	1/2	N/R	08 'U'	T-400-4C	Black	T-410-10	DN	.870
	1/2	N/R	08 'W'	T-400-42C	Black	T-410-10	DN	.976
	1/2	N/R	08 'Z'	ET400DC-M230S	Black	T-410-10	DN	0.940
H10410	5/8	N/R	10 'U'	T-400-64C	Black	T-410-10	DN	1.000
	5/8	N/R	10 'W'	T-440-85C	BK/WH	T-440-80R	UP	1.132
	5/8	N/R	10 'Z'	T-440-85C	Pink	ET4000SR-M560A	UP	1.055
H10412	3/4	N/R	12 'S'	T-400-5C	Yellow	T-410-41	UP	1.177
	3/4	N/R	12 'U'	T-400-5C	Black	T-410-10	DN	1.160
	3/4	N/R	12 'W'	T-440-86C	BK/BU	T-440-82R	UP	1.260
	3/4	N/R	12 'Z'	T-440-86C	Brown	ET4000SR-M405A	UP	1.250
H10416	1	N/R	16 'S'	T-400-6C	Yellow	T-410-41	UP	1.465
	1	N/R	16 'U'	T-400-6C	Black	T-410-10	DN	1.450
	1	N/R	16 'W'	T-440-87C	BK/WH	T-440-80R	UP	1.587
	1	N/R	16 'Z'	ET4000DC-M380S	Orange	T-410-93	UP	1.590
H10420	1-1/4	N/R	20 'S'	T-400-12	Black	T-410-10	DN	1.790
	1-1/4	N/R	20 'U'	T-400-12	Black	T-410-10	DN	1.785
H10504	1/4	N/R	04 'U'	T-400-2C	Black	T-410-10	UP	.610
H10506	3/8	N/R	06 'U'	T-400-3C	Black	T-410-10	UP	.788
H10508	1/2	N/R	08 'U'	T-400-4C	Silver	T-410-11	UP	.940
H10512	3/4	N/R	12 'U'	T-400-5C	Silver	T-410-11	UP	1.232

Note:
T-410-25 adapter die ring required when using T-400 series collets.

BK=Black **BU**=Blue **OR**=Orange
RD=Red **TN**=Tan **WH**=White
YW=Yellow **SV**=Silver **MG**=Magenta
GY=Gray **GR**=Green **BR**=Brown

Tooling Selector Chart

T-440 & ET4000

HOSE TYPE	HOSE I.D. (IN.)	SKIVE TOOL	HOSE END PREFIX	COLLET PART #	SPACER RING COLOR	SPACER RING PART #	FLAT SIDE UP/DN	NOMINAL CRIMP DIA. (IN.)
H10516	1	N/R	16 'U'	T-400-6C	Silver	T-410-11	DN	1.435
H11404	1/4	N/R	04 'S'	T-400-2C	Green	T-410-39	UP	.520
	1/4	N/R	04 'U'	T-400-2C	Green	T-410-39	UP	.520
H11406	3/8	N/R	06 'S'	T-400-3C	Green	T-410-39	UP	.695
	3/8	N/R	06 'U'	T-400-3C	Green	T-410-39	UP	.695
H11408	1/2	N/R	08 'S'	T-400-4C	Black	T-410-10	DN	.860
	1/2	N/R	08 'U'	T-400-4C	Green	T-410-39	UP	.830
H11504	1/4	N/R	04 'U'	T-400-2C	Black	T-410-10	UP	.610
H11506	3/8	N/R	06 'U'	T-400-3C	Black	T-410-10	UP	.788
H11508	1/2	N/R	08 'U'	T-400-4C	Silver	T-410-11	UP	.940
H11512	3/4	N/R	12 'U'	T-400-5C	Silver	T-410-11	UP	1.232
H11516	1	N/R	16 'U'	T-400-6C	Silver	T-410-11	UP	1.522
H11520	1-1/4	N/R	20 'U'	T-400-12	Silver	T-410-11	UP	1.862
H14504	1/4	N/R	04 'M'	T-400-109C	Yellow	T-410-41	UP	.630
	1/4	N/R	04 'S'	T-400-2C	Green	T-410-39	UP	.520
	1/4	N/R	04 'U'	T-400-2C	Green	T-410-39	UP	.520
	1/4	N/R	04 'W'	T-400-40C	BK/TN	T-440-78R	UP	.678
	1/4	N/R	04 'Z'	ET400DC-M150S	Purple	ET4000SR-M100A	UP	.612
H145R04	1/4	N/R	04 'Z'	ET400DC-M150S	Purple	ET1000SR-M100A	UP	.612
H14506	3/8	N/R	06 'M'	T-400-110C	Yellow	T-410-41	UP	.765
	3/8	N/R	06 'S'	T-400-3C	Green	T-410-39	UP	.695
	3/8	N/R	06 'U'	T-400-3C	Green	T-410-39	UP	.695
	3/8	N/R	06 'W'	T-400-41C	Green	T-410-39	UP	.782
	3/8	N/R	06 'Z'	ET400DC-M195S	Green	T-410-39	UP	.775
H145R06	3/8	N/R	06 'Z'	ET400DC-M195S	Green	T-400-37	UP	.775
H14508	1/2	N/R	08 'M'	T-400-111C	Yellow	T-410-41	UP	.935
	1/2	N/R	08 'S'	T-400-4C	Yellow	T-410-41	DN	.870
	1/2	N/R	08 'U'	T-400-4C	Yellow	T-410-41	DN	.870
	1/2	N/R	08 'W'	T-400-42C	Black	T-410-10	DN	.976
	1/2	N/R	08 'Z'	ET400DC-M230S	Purple	ET4000SR-M100A	UP	.920
H145R08	1/2	N/R	08 'Z'	ET400DC-M230S	Purple	ET1000SR-M100A	UP	.920
H14510	5/8	N/R	10 'U'	T-400-64C	Yellow	T-410-41	UP	1.010
	5/8	N/R	10 'W'	T-440-85C	N/R	N/R	N/R	1.149
	5/8	N/R	10 'Z'	T-440-85C	BK/MG	ET4000SR-M215A**	UP	1.115
H145R10	5/8	N/R	10 'Z'	T-440-85C	BK/MG	ET4000SR-M215A	UP	1.115
H14512	3/4	N/R	12 'S'	T-400-5C	Yellow	T-410-41	DN	1.160
	3/4	N/R	12 'U'	T-400-5C	Yellow	T-410-41	DN	1.160
	3/4	N/R	12 'W'	T-440-86C	BK/OR	T-440-81R	UP	1.293
	3/4	N/R	12 'Z'	T-440-86C	Orange	T-410-93	UP	1.275
H145R12	3/4	N/R	12 'Z'	T-440-86C	Orange	T-410-93	UP	1.275
H14516	1	N/R	16 'S'	T-400-6C	Yellow	T-410-41	DN	1.445
	1	N/R	43016 'U'	T-410-6CN	Orange	T-410-93	UP	1.655
	1	N/R	16 'W'	T-440-87C	BK/WH	T-440-80R	UP	1.587
	1	N/R	16 'Z'	ET4000DC-M380S	BK/BU	T-440-82R	UP	1.575
H145R16	1	N/R	16 'Z'	ET420DC-M380S	BK/BU	T-420-82R	UP	1.575
H14604	1/4	N/R	04 'U'	T-400-2C	Green	T-410-39	UP	.520
H14606	3/8	N/R	06 'U'	T-400-3C	Green	T-410-39	UP	.695
H14608	1/2	N/R	08 'U'	T-400-4C	Green	T-410-39	UP	.830
H16604	3/16	N/R	06904 'E'	T-400-54C	Yellow	T-410-41	UP	.525
H16605	1/4	N/R	06905 'E'	T-400-55C	Black	T-410-10	UP	.585
H16606	5/16	N/R	06906 'E'	T-400-56C	Black	T-410-10	UP	.680
H16608	13/32	N/R	06908 'E'	T-400-57C	Yellow	T-410-41	UP	.765
H16610	1/2	N/R	06910 'E'	T-400-58C	Black	T-410-10	UP	.910
H16612	5/8	N/R	06912 'E'	T-400-59C	Silver	T-410-11	UP	1.080
H16616	7/8	N/R	06916 'E'	T-400-60C	Black	T-410-10	UP	1.275
H16620	1-1/8	N/R	06920 'E'	T-400-61C	Yellow	T-410-41	UP	1.520
H16904	3/16	N/R	06904 'E'	T-400-54C	Yellow	T-410-41	UP	.525
H16905	1/4	N/R	06905 'E'	T-400-55C	Black	T-410-10	UP	.585

Note:
T-410-25 adapter die ring required when using T-400 series collets.

BK=Black **BU**=Blue **OR**=Orange
RD=Red **TN**=Tan **WH**=White
YW=Yellow **SV**=Silver **MG**=Magenta
GY=Gray **GR**=Green **BR**=Brown

Tooling Selector Chart

T-440 & ET4000

HOSE TYPE	HOSE I.D. (IN.)	SKIVE TOOL	HOSE END PREFIX	COLLET PART #	SPACER RING COLOR	SPACER RING PART #	FLAT SIDE UP/DN	NOMINAL CRIMP DIA. (IN.)
H16906	5/16	N/R	06906 'E'	T-400-56C	Black	T-410-10	UP	.680
H16908	13/32	N/R	06908 'E'	T-400-57C	Yellow	T-410-41	UP	.765
H16910	1/2	N/R	06910 'E'	T-400-58C	Black	T-410-10	UP	.910
H16912	5/8	N/R	06912 'E'	T-400-59C	Silver	T-410-11	UP	1.080
H16916	7/8	N/R	06916 'E'	T-400-60C	Black	T-410-10	UP	1.275
H16920	1-1/8	N/R	06920 'E'	T-400-61C	Yellow	T-410-41	UP	1.520
H16924	1-3/8	N/R	06924 'E'	T-400-70	Black	T-410-10	UP	1.730
H19004	1/4	N/R	04 'W'	T-400-40C	Black	T-410-10	DN	.664
	1/4	N/R	04 'Z'	ET400DC-M150S	Purple	ET1000SR-M100A	UP	0.620
H190H04	1/4	N/R	04 'Z'	ET400DC-M150S	Purple	ET1000SR-M100A	UP	0.620
H19006	3/8	N/R	06 'W'	T-400-41C	Black	T-410-10	DN	.820
	3/8	N/R	06 'Z'	ET400DC-M195S	Green	T400-37	UP	0.770
H190H06	3/8	N/R	06 'Z'	ET400DC-M195S	Green	T-400-37	UP	.770
H19008	1/2	N/R	08 'W'	T-400-42C	Black	T-410-10	DN	.976
	1/2	N/R	08 'Z'	ET400DC-M230S	Black	T-410-10	DN	.940
H190H08	1/2	N/R	08 'Z'	ET400DC-M230S	Black	T-400-10	DN	.940
H19010	5/8	N/R	10 'W'	T-440-85C	BK/WH	T-440-80R	UP	1.132
	5/8	N/R	10 'Z'	T-440-85C	Pink	ET420SR-M660A	UP	1.055
H190H10	5/8	N/R	10 'Z'	T-440-85C	Pink	ET420SR-M660A	UP	1.055
H19012	3/4	N/R	12 'W'	T-440-86C	BK/BU	T-440-82R	UP	1.260
	3/4	N/R	12 'Z'	T-440-86C	Brown	ET420SR-M495A	UP	1.250
H190H12	3/4	N/R	12 'Z'	T-440-86C	Brown	ET420SR-M495A	UP	1.250
H19016	1	N/R	16 'W'	T-440-87C	BK/WH	T-440-80R	UP	1.587
	1	N/R	16 'Z'	ET4000DC-M380S	Orange	T-420-29	UP	1.590
H190H16	1	N/R	16 'Z'	ET4000DC-M380S	Orange	T-420-29	UP	1.590
H19020	1-1/4	N/R	20 'Z'	ET4000DC-M420S	N/R	N/R	N/R	1.800
H190H20	1-1/4	N/R	20 'Z'	ET4000DC-M420S	N/R	N/R	N/R	1.800
H19024	1-1/2	N/R	24 'Z'	ET4000DC-M535S	N/R	N/R	N/R	2.181
H19032	2	N/R	32 'Z'	ET4000DC-M550S	N/R	N/R	N/R	2.701
H20904	1/4	N/R	04 'E'	T-400-31C	Black	T-410-10	DN	.455
H20905	5/16	N/R	05 'E'	T-400-32C	Black	T-410-10	DN	.555
H20906	3/8	N/R	06 'E'	T-400-33C	Black	T-410-10	DN	.615
H20908	1/2	N/R	08 'E'	T-400-34C	Black	T-410-10	DN	.765
H22904	3/16	N/R	06904 'E'	T-400-54C	Yellow	T-410-41	UP	.525
	3/16	N/R	22904 'P'	T-400-80C	Yellow	T-410-41	UP	.505
H22906	5/16	N/R	06906 'E'	T-400-56C	Black	T-410-10	UP	.680
	5/16	N/R	22906 'P'	T-400-81C	Black	T-410-10	DN	.650
H22908	13/32	N/R	06908 'E'	T-400-57C	Yellow	T-410-41	UP	.765
	13/32	N/R	22908 'P'	T-400-82C	Black	T-410-10	DN	.775
H22910	1/2	N/R	06910 'E'	T-400-58C	Black	T-410-10	UP	.910
	1/2	N/R	22910 'P'	T-400-83C	Black	T-410-10	DN	.875
H22912	5/8	N/R	06912 'E'	T-400-59C	Silver	T-410-11	UP	1.080
H22916	7/8	N/R	06916 'E'	T-400-60C	Black	T-410-10	UP	1.275
H23904	3/16	N/R	069 'E'	T-400-54C	Yellow	T-410-41	UP	.525
	3/16	N/R	229 'P'	T-400-80C	Black	T-410-10	DN	.480
H23906	5/16	N/R	069 'E'	T-400-56C	Black	T-410-10	UP	.680
	5/16	N/R	229 'P'	T-400-81C	Black	T-410-10	DN	.650
H23908	13/32	N/R	069 'E'	T-400-57C	Yellow	T-410-41	UP	.765
	13/32	N/R	229 'P'	T-400-82C	Black	T-410-10	DN	.775
H23910	1/2	N/R	069 'E'	T-400-58C	Black	T-410-10	UP	.910
	1/2	N/R	229 'P'	T-400-83C	Black	T-410-10	DN	.875
H23912	5/8	N/R	069 'E'	T-400-59C	Silver	T-410-11	UP	1.080
H23916	7/8	N/R	069 'E'	T-400-60C	Black	T-410-10	UP	1.275
H23920	1-1/8	N/R	069 'E'	T-400-61C	Yellow	T-410-41	UP	1.510
H24303	3/16	N/R	03 'E'	T-400-113C	Tan	T-410-42	UP	.355
H24304	1/4	N/R	04 'E'	T-400-31C	Green	T-410-39	UP	.405
H24305	5/16	N/R	05 'E'	T-400-32C	Red	T-410-40	UP	.475
H24306	3/8	N/R	06 'E'	T-400-33C	Red	T-410-40	UP	.545

Note:

T-410-25 adapter die ring required when using T-400 series collets.

BK=Black **BU**=Blue **OR**=Orange
RD=Red **TN**=Tan **WH**=White
YW=Yellow **SV**=Silver **MG**=Magenta
GY=Gray **GR**=Green **BR**=Brown

Tooling Selector Chart

T-440 & ET4000

HOSE TYPE	HOSE I.D. (IN.)	SKIVE TOOL	HOSE END PREFIX	COLLET PART #	SPACER RING COLOR	SPACER RING PART #	FLAT SIDE UP/DN	NOMINAL CRIMP DIA. (IN.)
H24308	1/2	N/R	08 'E'	T-400-34C	Red	T-410-40	UP	.695
H24312	3/4	N/R	12 'E'	T-400-35C	Red	T-410-40	UP	.978
H24316	1	N/R	16 'E'	T-400-36C	Red	T-410-40	UP	1.225
H24504	1/4	N/R	04 'M'	T-400-109C	Black	T-410-10	UP	.665
	1/4	N/R	04 'S'	T-400-2C	Yellow	T-410-41	DN	.560
	1/4	N/R	04 'U'	T-400-2C	Yellow	T-410-41	DN	.560
	1/4	N/R	04 'W'	T-400-40C	BK/TN	T-440-78R	UP	.678
	1/4	N/R	04 'Z'	ET400DC-M150S	Black	T-410-10	DN	.640
H245L04	1/4	N/R	04 'Z'	ET400DC-M150S	Black	T-410-10	DN	0.640
H24506	3/8	N/R	06 'M'	T-400-110C	Black	T-410-10	UP	.805
	3/8	N/R	06 'S'	T-400-3C	Yellow	T-410-41	DN	.740
	3/8	N/R	06 'U'	T-400-3C	Yellow	T-410-41	DN	.740
	3/8	N/R	06 'W'	T-400-41C	Black	T-410-10	DN	.820
	3/8	N/R	06 'Z'	ET400DC-M195S	Tan	T-410-112	UP	.800
H245L06	3/8	N/R	06 'Z'	ET400DC-M195S	Tan	T-400-112	UP	.800
H24508	1/2	N/R	08 'M'	T-400-111C	Yellow	T-410-41	UP	.940
	1/2	N/R	08 'S'	T-400-4C	Yellow	T-410-41	DN	.865
	1/2	N/R	08 'U'	T-400-4C	Yellow	T-410-41	DN	.865
	1/2	N/R	08 'W'	T-400-42C	BK/TN	T-440-78R	UP	.993
	1/2	N/R	08 'Z'	ET400DC-M230S	Lt. Green	ET1000SR-M190D	UP	.975
H245L08	1/2	N/R	08 'Z'	ET400DC-M230S	Lt Green	ET1000SR-M190D	Up	.975
H24510	5/8	N/R	10 'M'	T-410-30C	Orange	T-410-93	UP	1.085
H24510	5/8	N/R	10 'U'	T-400-64C	Yellow	T-410-41	UP	1.010
	5/8	N/R	10 'W'	T-440-85C	BK/WH	T-440-80R	UP	1.132
	5/8	N/R	10 'Z'	T-440-85C	BK/MG	ET4000SR-M215A**	UP	1.115
H245L10	5/8	N/R	10 'Z'	T-440-85C	BK/MG	ET4000SR-M215A	UP	1.115
H24512	3/4	N/R	12 'S'	T-400-5C	Yellow	T-410-41	DN	1.160
	3/4	N/R	12 'U'	T-400-5C	Yellow	T-410-41	DN	1.160
	3/4	N/R	43012 'U'	T-410-5CN	Orange	T-410-93	UP	1.365
	3/4	N/R	12 'W'	T-440-86C	BK/OR	T-440-81R	UP	1.293
	3/4	N/R	12 'Z'	T-440-86C	Brown	ET420SR-M495A	UP	1.245
H245L12	3/4	N/R	12 'Z'	T-440-86C	Brown	ET420SR-M495A	UP	1.245
H24516	1	N/R	16 'S'	T-400-6C	Yellow	T-410-41	UP	1.465
	1	N/R	16 'U'	T-400-6C	Yellow	T-410-41	UP	1.465
	1	N/R	43016 'U'	T-410-6CN	Orange	T-410-93	UP	1.660
	1	N/R	16 'W'	T-440-87C	BK/WH	T-440-80R	UP	1.587
	1	N/R	16 'Z'	ET4000DC-M380S	Brown	ET420SR-M495A	UP	1.565
H245L16	1	N/R	16 'Z'	ET4000DC-M380S	Brown	ET420SR-M495A	UP	1.565
H24520	1-1/4	N/R	20 'S'	T-400-12	Yellow	T-410-41	DN	1.795
	1-1/4	N/R	20 'U'	T-400-12	Yellow	T-410-41	DN	1.795
	1-1/4	N/R	43020 'U'	T-410-7CN	Orange	T-410-93	UP	1.990
	1-1/4	N/R	20 'Z'	ET4000DC-M480S	BK/BR	ET4000SR-M345A	UP	1.900
H245L20	1-1/4	N/R	20 'Z'	ET4000DC-M480S	BK/BR	ET4000SR-M345A	UP	1.900
H24524	1-1/2	N/R	24 'Z'	ET4000DC-M530S	N/R	N/R	N/R	2.155
H245L24	1-1/2	N/R	24 'Z'	ET4000DC-M530S	N/R	N/R	N/R	2.155
H24532	2	N/R	32 'Z'	ET4000DC-M550S	N/R	N/R	N/R	2.700
H245L32	2	N/R	32 'Z'	ET4000DC-M550S	N/R	N/R	N/R	2.700
H26504	1/4	N/R	26504 'P'	T-400-2C	Green	T-410-39	UP	.520
H26506	3/8	N/R	06 'E'	T-400-33C	Black	T-410-10	UP	.660
	3/8	N/R	26506 'P'	T-400-2C	Silver	T-410-11	UP	.640
H26508	1/2	N/R	08 'E'	T-400-34C	Black	T-410-10	UP	.810
	1/2	N/R	26508 'P'	T-400-3C	Black	T-410-10	UP	.788
H26512	3/4	N/R	12 'E'	T-400-35C	Black	T-410-10	UP	1.090
	3/4	N/R	26512 'P'	T-400-64C	Silver	T-410-11	UP	1.070
H26516	1	N/R	16 'E'	T-400-36C	Black	T-410-10	UP	1.340
H27504	1/4	N/R	26504 'P'	T-400-2C	Green	T-410-39	UP	.520
H27506	3/8	N/R	06 'E'	T-400-33C	Black	T-410-10	UP	.660
	3/8	N/R	26506 'P'	T-400-2C	Silver	T-410-11	UP	.640

Note:
T-410-25 adapter die ring required when using T-400 series collets.

BK=Black **BU**=Blue **OR**=Orange
RD=Red **TN**=Tan **WH**=White
YW=Yellow **SV**=Silver **MG**=Magenta
GY=Gray **GR**=Green **BR**=Brown

Tooling Selector Chart

T-440 & ET4000

HOSE TYPE	HOSE I.D. (IN.)	SKIVE TOOL	HOSE END PREFIX	COLLET PART #	SPACER RING COLOR	SPACER RING PART #	FLAT SIDE UP/DN	NOMINAL CRIMP DIA. (IN.)
H27508	1/2	N/R	08 'E'	T-400-34C	Black	T-410-10	UP	.810
	1/2	N/R	26508 'P'	T-400-3C	Black	T-410-10	UP	.788
H27512	3/4	N/R	12 'E'	T-400-35C	Black	T-410-10	UP	1.090
	3/4	N/R	26512 'P'	T-400-64C	Silver	T-410-11	UP	1.070
H27516	1	N/R	16 'E'	T-400-36C	Black	T-410-10	UP	1.340
H27703	3/16	N/R	03 'E'	T-400-113C	Tan	T-410-42	UP	.355
H27704	1/4	N/R	04 'E'	T-400-31C	Green	T-410-39	UP	.405
H27705	5/16	N/R	05 'E'	T-400-32C	Red	T-410-40	UP	.475
H27706	3/8	N/R	06 'E'	T-400-33C	Red	T-410-40	UP	.545
H27708	1/2	N/R	08 'E'	T-400-34C	Red	T-410-40	UP	.695
H27712	3/4	N/R	12 'E'	T-400-35C	Red	T-410-40	UP	.978
H27716	1	N/R	16 'E'	T-400-36C	Red	T-410-40	UP	1.225
H28004	1/4	N/R	04 'W'	T-400-40C	BK/TN	T-440-78R	UP	.678
	1/4	N/R	04 'Z'	ET400DC-M150S	Yellow	T-410-41	UP	0.665
H28006	3/8	N/R	06 'W'	T-400-41C	Black	T-410-10	DN	.820
	3/8	N/R	06 'Z'	ET400DC-M195S	Black	T-410-10	DN	0.815
H28008	1/2	N/R	08 'W'	T-400-42C	BK/TN	T-440-78R	UP	.992
	1/2	N/R	08 'Z'	ET400DC-M230S	Lt. Green	ET4000SR-M190D	UP	0.975
H28010	5/8	N/R	10 'W'	T-440-85C	BK/WH	T-440-80R	UP	1.132
	5/8	N/R	10 'Z'	T-440-85C	BK/MG	ET4000SR-M215A**	UP	1.115
H28012	3/4	N/R	12 'W'	T-440-86C	BK/OR	T-440-81R	UP	1.293
	3/4	N/R	12 'Z'	T-440-86C	Brown	ET4000SR-M405A	UP	1.245
H28016	1	N/R	16 'W'	T-440-87C	BK/WH	T-440-80R	UP	1.587
	1	N/R	16 'Z'	ET4000DC-M380S	Brown	ET4000SR-M405A	UP	1.565
H28020	1-1/4	N/R	20 'Z'	ET4000DC-M480S	BK/BR	ET4000SR-M345A	UP	1.900
H28024	1-1/2	N/R	24 'Z'	ET4000DC-M530S	N/R	N/R	N/R	2.151
H28032	2	N/R	32 'Z'	ET4000DC-M550S	N/R	N/R	N/R	2.7
H28504	1/4	N/R	04 'E'	T-400-31C	Black	T-410-10	UP	.500
	1/4	N/R	26504 'P'	T-400-2C	Green	T-410-39	UP	.520
H28506	3/8	N/R	06 'E'	T-400-33C	Black	T-410-10	UP	.660
	3/8	N/R	26506 'P'	T-400-2C	Silver	T-410-11	UP	.640
H28508	1/2	N/R	08 'E'	T-400-34C	Black	T-410-10	UP	.810
	1/2	N/R	26508 'P'	T-400-3C	Black	T-410-10	UP	.788
H28512	3/4	N/R	12 'E'	T-400-35C	Black	T-410-10	UP	1.090
	3/4	N/R	26512 'P'	T-400-64C	Silver	T-410-11	UP	1.070
H28516	1	N/R	16 'E'	T-400-36C	Black	T-410-10	UP	1.340
H29004	1/4	N/R	04 'W'	T-400-40C	Black	T-410-10	UP	.722
	1/4	N/R	04 'Z'	ET400DC-M150S	Lt. Green	ET4000SR-M190D	UP	0.680
H290H04	1/4	N/R	04 'Z'	ET400DC-M150S	Lt Green	ET4000SR-M190D	UP	0.680
H29006	3/8	N/R	06 'W'	T-400-41C	BK/RD	T-440-79R	UP	.854
	3/8	N/R	06 'Z'	ET400DC-M195S	Yellow	T-410-41	UP	0.835
H290H06	3/8	N/R	06 'Z'	ET400DC-M195S	Yellow	T-410-41	UP	0.835
H29008	1/2	N/R	08 'W'	T-400-42C	BK/RD	T-440-79R	UP	1.007
	1/2	N/R	08 'Z'	ET400DC-M230S	Black	T-410-10	UP	.990
H290H08	1/2	N/R	08 'Z'	ET400DC-M230S	Black	T-410-10	UP	.990
H29010	5/8	N/R	10 'W'	T-440-85C	N/R	N/R	N/R	1.149
	5/8	N/R	10 'Z'	T-440-85C	BK/WH	T-440-80R	UP	1.130
H290H10	5/8	N/R	10 'Z'	T-440-85C	BK/WH	T-440-80R	UP	1.130
H29012	3/4	N/R	12 'W'	T-440-86C	N/R	N/R	N/R	1.317
	3/4	N/R	12 'Z'	T-440-86C	BK/MG	ET4000SR-M215A**	UP	1.280
H290H12	3/4	N/R	12 'Z'	T-440-86C	BK/MG	ET4000SR-M215A	UP	1.280
H29016	1	N/R	16 'W'	T-440-87C	N/R	N/R	N/R	1.607
	1	N/R	16 'Z'	ET4000DC-M380S	N/R	N/R	N/R	1.640
H290H16	1	N/R	16 'Z'	ET4000DC-M380S	N/R	N/R	N/R	1.640
H29020	1-1/4	N/R	20 'Z'	T-410-7CN	BK/PR	ET4000SR-M180S	UP	2.000
	1-1/4	N/R	20 'Z'	ET4000DC-M480S	N/R	N/R	N/R	1.960
H290H20	1-1/4	N/R	20 'Z'	T-410-7CN	BK/PR	ET4000SR-M180A	UP	2.000
H29024	1-1/2	N/R	24 'Z'	ET4000DC-M560S	Purple	ET4000SR-M180S	UP	2.270

Note:

T-410-25 adapter die ring required when using T-400 series collets.

BK=Black **BU**=Blue **OR**=Orange
RD=Red **TN**=Tan **WH**=White
YW=Yellow **SV**=Silver **MG**=Magenta
GY=Gray **GR**=Green **BR**=Brown

Tooling Selector Chart

T-440 & ET4000

HOSE TYPE	HOSE I.D. (IN.)	SKIVE TOOL	HOSE END PREFIX	COLLET PART #	SPACER RING COLOR	SPACER RING PART #	FLAT SIDE UP/DN	NOMINAL CRIMP DIA. (IN.)
H290H24	1 1/2	N/R	24 'Z'	ET4000DC-M560S	Purple	ET4000SR-M180A	UP	2.270
H29032	2	N/R	32 'Z'	ET4000DC-M570S	N/R	N/R	N/R	2.770
H290H32	2	N/R	32 'Z'	ET4000DC-M570S	N/R	N/R	N/R	2.770
H32406	3/8	N/R	06 'U'	T-400-3C	Black	T-410-10	UP	.785
H32504	1/4	N/R	04 'U'	T-400-2C	Black	T-410-10	UP	.610
H32506	3/8	N/R	06 'U'	T-400-3C	Black	T-410-10	UP	.795
H32508	1/2	N/R	08 'U'	T-400-4C	Yellow	T-410-41	UP	.885
H32512	3/4	N/R	12 'U'	T-400-5C	Black	T-410-10	UP	1.215
H32516	1	N/R	16 'U'	T-400-6C	Silver	T-410-11	UP	1.525
H33503	3/16	N/R	33603 'E'	T-400-120C	Black	T-410-10	UP	.540
H33504	1/4	N/R	33604 'E'	T-400-121C	Black	T-410-10	UP	.667
H33506	3/8	N/R	33606 'E'	T-400-122C	Black	T-410-10	UP	.770
H33508	1/2	N/R	33608 'E'	T-400-123C	Black	T-410-10	UP	.895
H33603	3/16	N/R	33603 'E'	T-400-120C	Black	T-410-10	UP	.540
H33604	1/4	N/R	33604 'E'	T-400-121C	Black	T-410-10	UP	.667
H33606	3/8	N/R	33606 'E'	T-400-122C	Black	T-410-10	UP	.770
H33608	1/2	N/R	33608 'E'	T-400-123C	Black	T-410-10	UP	.895
H33806	3/8	N/R	33806 'P'	T-400-102C	Black	T-410-10	DN	.700
H33808	1/2	N/R	33808 'P'	T-400-103C	Black	T-410-10	DN	.795
H34504	1/4	N/R	04 'M'	T-400-109C	Yellow	T-410-41	UP	.630
	1/4	N/R	04 'W'	T-400-40C	Black	T-410-10	DN	.664
	1/4	N/R	04 'Z'	ET400DC-M150S	Tan	T-410-42	UP	.625
H34506	3/8	N/R	06 'M'	T-400-110C	Yellow	T-410-41	UP	.765
	3/8	N/R	06 'W'	T-400-41C	Green	T-410-39	UP	.782
	3/8	N/R	06 'Z'	ET400DC-M195S	Green	T-410-39	UP	.775
H34508	1/2	N/R	08 'M'	T-400-111C	Yellow	T-410-41	DN	.915
	1/2	N/R	08 'W'	T-400-42C	Black	T-410-10	DN	.976
	1/2	N/R	08 'Z'	ET400DC-M230S	Black	T-410-10	DN	.940
H35006	3/8	N/R	06 'M'	T-400-110C	Black	T-410-10	UP	.805
	3/8	N/R	06 'W'	T-400-41C	Black	T-410-10	DN	.820
	3/8	N/R	06 'U'	T-400-3C	Yellow	T-410-41	DN	.740
	3/8	N/R	06 'Z'	ET400DC-M195S	Black	T-410-10	DN	.815
H35008	1/2	N/R	08 'M'	T-400-111C	Yellow	T-410-41	UP	.945
	1/2	N/R	08 'W'	T-400-42C	BK/TN	T-440-78R	UP	.993
	1/2	N/R	08 'U'	T-400-4C	Yellow	T-410-41	DN	.865
	1/2	N/R	08 'Z'	ET400DC-M230S	Lt. Green	ET4000SR-M190D	UP	.975
H35010	5/8	N/R	10 'M'	T-410-30C	N/R	N/R	N/R	1.120
	5/8	N/R	10 'W'	T-440-85C	BK/WH	T-440-80R	UP	1.132
	5/8	N/R	10 'Z'	T-440-85C	BK/WH	T-440-80R	UP	1.130
H35012	3/4	N/R	43012 'U'	T-410-5CN	N/R	N/R	N/R	1.413
H35016	1	N/R	43016 'U'	T-410-6CN	N/R	N/R	N/R	1.705
H36606	5/16	N/R	06906 'E'	T-400-56C	Black	T-410-10	UP	.680
H36608	13/32	N/R	06908 'E'	T-400-57C	Yellow	T-410-41	UP	.765
H40006	1/4	N/R	04 'Z'	ET400DC-M195S	Yellow	T-400-62	UP	.835
H40008	3/8	N/R	06 'Z'	ET400DC-M230S	Black	T-400-10	UP	.990
H40010	5/8	N/R	10 'M'	T-410-30C	N/R	N/R	N/R	1.120
	5/8	N/R	10 'W'	T-440-85C	N/R	N/R	N/R	1.149
	5/8	N/R	10 'Z'	T-440-85C	BK/WH	T-440-80R	UP	1.129
H40010	1/2	N/R	08 'Z'	T-440-85C	BK/WH	T-400-80R	UP	1.129
H40012	3/4	N/R	12 'W'	T-440-86C	N/R	N/R	N/R	1.317
	3/4	N/R	12 'Z'	T-440-86C	BK/MG	ET4000SR-M215A**	UP	1.286
H40012	5/8	N/R	10 'Z'	T-440-86C	BK/MG	ET420SR-M255A	UP	1.286
H42104	1/4	N/R	04 'Z'	ET400DC-M150S	BK/RD	T-400-47R	UP	0.665
H42106	3/8	N/R	06 'Z'	ET400DC-M195S	Yellow	T-400-62	UP	0.835
H42504	1/4	N/R	04 'S'	T-400-2C	Black	T-410-10	UP	.610
	1/4	N/R	04 'U'	T-400-2C	Black	T-410-10	UP	.610
H42504	1/4	N/R	04 'W'	T-400-40C	Black	T-410-10	UP	.722
	1/4	N/R	04 'Z'	ET400DC-M150S	Yellow	T-410-41	UP	.665

Note:
T-410-25 adapter die ring required when using T-400 series collets.

*Qualified in ET4000 machine only.
Requires the ET4000AR-002 base adapter ring.

**The slot on the spacer ring must rest against the locator bracket.

BK=Black **BU**=Blue **OR**=Orange
RD=Red **TN**=Tan **WH**=White
YW=Yellow **SV**=Silver **MG**=Magenta
GY=Gray **GR**=Green **BR**=Brown

Tooling Selector Chart

T-440 & ET4000

HOSE TYPE	HOSE I.D. (IN.)	SKIVE TOOL	HOSE END PREFIX	COLLET PART #	SPACER RING COLOR	SPACER RING PART #	FLAT SIDE UP/DN	NOMINAL CRIMP DIA. (IN.)
H42506	3/8	N/R	06 'S'	T-400-3C	Black	T-410-10	UP	.795
	3/8	N/R	06 'U'	T-400-3C	Black	T-410-10	UP	.795
	3/8	N/R	06 'W'	T-400-41C	BK/RD	T-440-79R	UP	.854
	3/8	N/R	06 'Z'	ET400DC-M195S	Yellow	T-410-41	UP	.835
H42508	1/2	N/R	08 'S'	T-400-4C	Black	T-410-10	UP	.920
	1/2	N/R	08 'U'	T-400-4C	Black	T-410-10	UP	.915
	1/2	N/R	08 'W'	T-400-42C	BK/RD	T-440-79R	UP	1.007
	1/2	N/R	08 'Z'	ET400DC-M230S	Black	T-410-10	UP	0.990
H42510	5/8	N/R	10 'U'	T-400-64C	Black	T-410-10	UP	1.050
	5/8	N/R	10 'W'	T-440-85C	BK/WH	T-440-80R	UP	1.132
	5/8	N/R	10 'Z'	T-440-85C	BK/WH	T-440-80R	UP	1.130
H42512	3/4	N/R	12 'S'	T-400-5C	Black	T-410-10	UP	1.210
	3/4	N/R	12 'U'	T-400-5C	Black	T-410-10	UP	1.205
	3/4	N/R	43012 'U'	T-410-5CN	N/R	N/R	N/R	1.410
	3/4	N/R	12 'W'	T-440-86C	N/R	N/R	N/R	1.317
	3/4	N/R	12 'Z'	T-440-86C	BK/MG	ET4000SR-M215A**	UP	1.280
H42516	1	N/R	16 'S'	T-400-6C	Silver	T-410-11	UP	1.525
	1	N/R	16 'U'	T-400-6C	Silver	T-410-11	UP	1.525
	1	N/R	43016 'U'	T-410-6CN	N/R	N/R	N/R	1.707
	1	N/R	16 'W'	T-440-87C	N/R	N/R	N/R	1.607
	1	N/R	16 'Z'	ET4000DC-M380S	N/A	N/A	N/A	1.630
H42520	1-1/4	N/R	20 'S'	T-400-12	Silver	T-410-11	UP	1.885
	1-1/4	N/R	20 'U'	T-400-12	Black	T-410-10	UP	1.850
	1-1/4	N/R	43020 'U'	T-410-7CN	N/R	N/R	N/R	2.035
	1-1/4	N/R	20 'Z'	ET4000DC-M480S	N/A	N/A	N/A	1.960
H42524	1-1/2	N/R	43024 'U'	T-410-8N	N/R	N/R	N/R	2.270
H42532	2	N/R	43032 'U'	T-410-9N	N/R	N/R	N/R	2.890
H42908	13/32	N/R	057 'P'	T-400-102C	Green	T-410-39	UP	.660
H42910	1/2	N/R	057 'P'	T-400-103C	Green	T-410-39	UP	.750
H43008	1/2	N/R	43008 'U'	T-410-4CN	N/R	N/R	N/R	1.150
H430R08	1/2	N/R	430U	T-420-4CN	N/R	N/R	N/R	1.150
H43012	3/4	N/R	43012 'U'	T-410-5CN	N/R	N/R	N/R	1.406
H430R12	3/4	N/R	430U	T-420-5CN	N/R	N/R	N/R	1.406
H43016	1	N/R	43016 'U'	T-410-6CN	N/R	N/R	N/R	1.705
H430R16	1	N/R	430U	T-420-6CN	N/R	N/R	N/R	1.705
H43020	1-1/4	N/R	43020 'U'	T-410-7CN	N/R	N/R	N/R	2.035
H430R20	1-1/4	N/R	430U	T-420-7CN	N/R	N/R	N/R	2.035
H43024	1-1/2	N/R	43024 'U'	T-410-8N	N/R	N/R	N/R	2.285
H430R24	1-1/2	N/R	430U	T-410-8CN	N/R	N/R	N/R	2.285
H43032	2	N/R	43032 'U'	T-410-9N	N/R	N/R	N/R	2.895
H430R32	2	N/R	430U	T-410-9CN	N/R	N/R	N/R	2.895
H43504	1/4	N/R	04 'E'	T-400-31C	Black	T-410-10	DN	.455
H43505	5/16	N/R	05 'E'	T-400-32C	Black	T-410-10	DN	.555
H43506	3/8	N/R	06 'E'	T-400-33C	Black	T-410-10	DN	.615
H43508	1/2	N/R	08 'E'	T-400-34C	Black	T-410-10	DN	.765
H43512	3/4	N/R	12 'E'	T-400-35C	Black	T-410-10	DN	1.035
H43516	1	N/R	16 'E'	T-400-36C	Black	T-410-10	DN	1.295
H43604	1/4	N/R	04 'E'	T-400-31C	Black	T-410-10	DN	.455
H43605	5/16	N/R	05 'E'	T-400-32C	Black	T-410-10	DN	.555
H43606	3/8	N/R	06 'E'	T-400-33C	Black	T-410-10	DN	.615
H43608	1/2	N/R	08 'E'	T-400-34C	Black	T-410-10	DN	.765
H43612	3/4	N/R	12 'E'	T-400-35C	Black	T-410-10	DN	1.035
H43616	1	N/R	16 'E'	T-400-36C	Black	T-410-10	DN	1.295
H46412	3/4	N/R	4SP12W	ET4000DC-4S12	BK/WH	T-440-80R	UP	1.425
H46416	1	N/R	4SP16W	ET4000DC-4S16	BK/WH	T-440-80R	UP	1.768
H46420	1-1/4	N/R	4SP20W	ET4000DC-4S20*	N/A	N/A	N/A	2.106
H46424	1-1/2	N/R	4SP24W	ET4000DC-4S24*	BK/PU	ET4000SR-M180A**	UP	2.378
H46432	2	N/R	4SP32W	ET4000DC-4S32*	N/A	N/A	N/A	2.898

Note:

T-410-25 adapter die ring required when using T-400 series collets.

*Qualified in ET4000 machine only. Requires the ET4000AR-002 base adapter ring.

**The slot on the spacer ring must rest against the locator bracket.

BK=Black **BU**=Blue **OR**=Orange
RD=Red **TN**=Tan **WH**=White
YW=Yellow **SV**=Silver **MG**=Magenta
GY=Gray **GR**=Green **BR**=Brown

Tooling Selector Chart

T-440 & ET4000

HOSE TYPE	HOSE I.D. (IN.)	SKIVE TOOL	HOSE END PREFIX	COLLET PART #	SPACER RING COLOR	SPACER RING PART #	FLAT SIDE UP/DN	NOMINAL CRIMP DIA. (IN.)
H47008	1/2	T-410-50	47008 'E'	T-470-8C	N/R	N/R	N/R	.980
H47012	3/4	T-410-52	47012 'E'	T-470-12C	N/R	N/R	N/R	1.250
	3/4	T-410-52	57012 'S'	T-470-12C	N/R	N/R	N/R	1.250
	3/4	N/R	4SP12W	ET4000DC-4S12	N/R	N/R	N/R	1.445
H47016	1	T-410-53	47016 'E'	T-470-16C	N/R	N/R	N/R	1.560
	1	T-410-53	57016 'S'	T-470-16C	N/R	N/R	N/R	1.560
	1	N/R	4SP16W	ET4000DC-4S12	N/R	N/R	N/R	1.787
H47020	1-1/4	T-410-54	47020 'E'	T-470-20	N/R	N/R	N/R	2.025
	1-1/4	T-410-54	57020 'S'	T-470-20	N/R	N/R	N/R	2.025
	1-1/4	N/R	6SP20W	ET4000DC-6S20	N/R	N/R	N/R	2.248
H47024	1-1/2	T-410-55	47024 'E'	T-470-24	N/R	N/R	N/R	2.365
	1-1/2	T-410-55	57024 'S'	T-470-24	N/R	N/R	N/R	2.365
	1-1/2	N/R	6SP24W	ET4000DC-6S24	BK/PU	ET4000SR-M180A**	N/R	2.524
H47032	2	T-410-56	47032 'E'	T-440-32	N/R	N/R	N/R	2.975
	2	T-410-56	57032 'S'	T-440-32	N/R	N/R	N/R	2.975
	2	N/R	6SP32W	ET4000DC-6S32	N/R	N/R	N/R	3.114
H48516		N/R	4SP16W	ET4000DC-4S16	BK/WH	T-440-80R	UP	1.768
H48520		N/R	6SP20W	ET4000DC-6S20	BK/MG	ET4000SR-M215A**	UP	2.213
H48524		N/R	6SP24W	ET4000DC-6S24	BK/PU	ET4000SR-M180A**	UP	2.525
H54504	1/4	N/R	04 'S'	T-400-2C	Yellow	T-410-41	DN	.560
	1/4	N/R	04 'U'	T-400-2C	Yellow	T-410-41	DN	.560
	1/4	N/R	04 'W'	T-400-40C	Black	T-410-10	DN	.664
H54506	3/8	N/R	06 'S'	T-400-3C	Green	T-410-39	UP	.695
	3/8	N/R	06 'U'	T-400-3C	Green	T-410-39	UP	.695
	3/8	N/R	06 'W'	T-400-41C	Black	T-410-10	DN	.820
H54508	1/2	N/R	08 'M'	T-400-111C	Yellow	T-410-41	UP	.940
	1/2	N/R	08 'S'	T-400-4C	Black	T-410-10	DN	.865
	1/2	N/R	08 'U'	T-400-4C	Yellow	T-410-41	DN	.865
	1/2	N/R	08 'W'	T-400-42C	BK/TN	T-440-78R	UP	.992
H54510	5/8	N/R	10 'U'	T-400-64C	Yellow	T-410-41	UP	1.010
	5/8	N/R	10 'W'	T-440-85C	BK/WH	T-440-80R	UP	1.132
H54512	3/4	N/R	12 'S'	T-400-5C	Yellow	T-410-41	DN	1.155
	3/4	N/R	12 'U'	T-400-5C	Yellow	T-410-41	DN	1.155
	3/4	N/R	12 'W'	T-440-86C	BK/OR	T-440-81R	UP	1.293
H54516	1	N/R	43016 'U'	T-410-6CN	N/R	N/R	N/R	1.705
	1	N/R	16 'W'	T-440-87C	BK/WH	T-440-80R	UP	1.587
H56904	3/16	N/R	06904 'E'	T-400-54C	Yellow	T-410-41	UP	.525
H56905	1/4	N/R	06905 'E'	T-400-55C	Black	T-410-10	UP	.585
H56906	5/16	N/R	06906 'E'	T-400-56C	Black	T-410-10	UP	.680
H56908	13/32	N/R	06908 'E'	T-400-57C	Yellow	T-410-41	UP	.765
H56910	1/2	N/R	06910 'E'	T-400-58C	Black	T-410-10	UP	.910
H56912	5/8	N/R	06912 'E'	T-400-59C	Silver	T-410-11	UP	1.080
H56916	7/8	N/R	06916 'E'	T-400-60C	Black	T-410-10	UP	1.275
H56920	1-1/8	N/R	06920 'E'	T-400-61C	Black	T-410-10	DN	1.485
H75706	5/16	N/R	75706 'E'	T-400-105C	Black	T-410-10	DN	.495
H75708	13/32	N/R	75708 'E'	T-400-106C	Black	T-410-10	DN	.595
H75710	1/2	N/R	75710 'E'	T-400-107C	Black	T-410-10	DN	.695
H75712	5/8	N/R	75712 'E'	T-400-108C	Black	T-410-10	DN	.850
H9610-6	3/8	N/R	06 'Z'	ET400DC-M195S	Purple	ET4000SR-M100A	UP	.785
H9610-8	1/2	N/R	08 'Z'	ET400DC-M230S	Black	T-410-10	DN	.940

Note:

T-410-25 adapter die ring required when using T-400 series collets.

*Qualified in ET4000 machine only. Requires the ET4000AR-002 base adapter ring.

**The slot on the spacer ring must rest against the locator bracket.

BK=Black **BU**=Blue **OR**=Orange
RD=Red **TN**=Tan **WH**=White
YW=Yellow **SV**=Silver **MG**=Magenta
GY=Gray **GR**=Green **BR**=Brown

Tooling Selector Chart

T-475

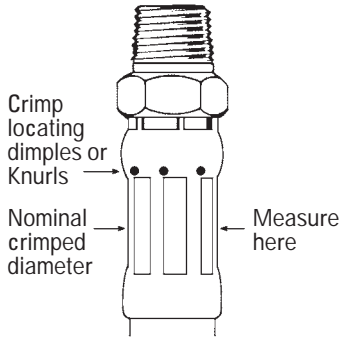
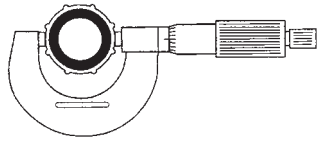

Note:
In larger sizes, calipers may be used; however, in smaller sizes, and in the 'E' Series thermoplastic hose ends, a point micrometer will provide an accurate reading. Nominal crimp diameters are for Weatherhead hose and end fittings when crimped with Weatherhead Coll-O-Crimp tooling.

⚠ WARNING

Proper Selection of Hose Ends: Selection of the proper end fittings for the hose end application is essential to the proper operation and safe use of the hose and related equipment. Inadequate attention to the selection of the end fittings for your application can result in leaking or the hose ends blowing off the hose, leading to serious bodily injury or property damage. In order to avoid serious bodily injury or property damage resulting from selection of the wrong end fitting, you should carefully review the information in the Weatherhead Catalog W-HYOV-MC002-E.

⚠ WARNING

Coll-O-Crimp Hose, Hose Fittings and Assembly Equipment Compatibility: The Coll-O-Crimp Equipment

Package, Coll-O-Crimp End Fittings, and Coll-O-Crimp Hose have been engineered and designed as a complete hose assembly system. Each component of the Coll-O-Crimp hose assembly system is compatible with other Coll-O-Crimp components to which it relates. Component compatibility, along with the use of quality components, insures the production of reliable hose assemblies when assembled properly. The use or intermixing of fittings and hose not specifically engineered and designed for use with each other and Coll-O-Crimp equipment is not recommended and may result in the production of unsafe or unreliable hose assemblies. This can result in hose assembly leakage, hose separation or other failures which can cause serious bodily injury or property damage from spraying

fluids, flying projectiles, or other substances. Eaton's Weatherhead warranty is limited to apply only when Coll-O-Crimp end fittings and compatible Coll-O-Crimp hose are used with Coll-O-Crimp assembly equipment. **Nominal Crimp Diameter Measurement:** Please remove this chart and place near your Coll-O-Crimp equipment for reference. Measuring crimp diameters should be a part of the normal hose assembly procedure. To insure a proper crimp diameter reading, follow these steps.

1. Measure the diameter in the middle of crimped portion of the hose end.
2. Place the caliper in a position to allow a measurement across the pressed (flat) portion of the crimp.
3. See crimp diameters on following chart.

T-475

HOSE TYPE	HOSE I.D. (IN.)	SKIVE TOOL	HOSE END PREFIX	COLLET PART #	SPACER RING COLOR	SPACER RING PART #	FLAT SIDE UP/DN	NOMINAL CRIMP DIA. (IN.)
H75706	5/16	N/R	75706 'E'	T-475-105C	N/R	N/R	N/R	.556
H75708	13/32	N/R	75708 'E'	T-475-106C	N/R	N/R	N/R	.640
H75710	1/2	N/R	75710 'E'	T-475-107C	N/R	N/R	N/R	.742
H75712	5/8	N/R	75712 'E'	T-475-108C	N/R	N/R	N/R	.897

BK=Black BU=Blue OR=Orange
 RD=Red TN=Tan WH=White
 YW=Yellow SV=Silver MG=Magenta
 GY=Gray GR=Green BR=Brown

Tooling Selector Chart

ET1000

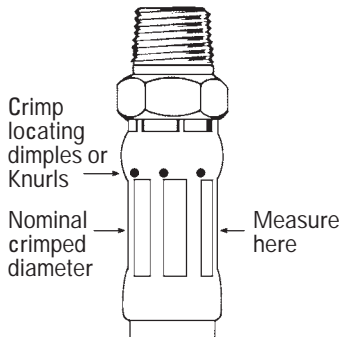
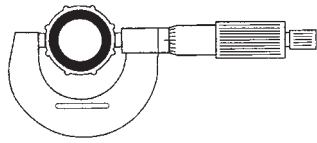

Note:
In larger sizes, calipers may be used; however, in smaller sizes, and in the 'E' Series thermoplastic hose ends, a point micrometer will provide an accurate reading. Nominal crimp diameters are for Weatherhead hose and end fittings when crimped with Weatherhead Coll-O-Crimp tooling.

Note:
ET1000AR-001 or T-420-25 adapter die ring required when using T-400 series collets

⚠ WARNING

Proper Selection of Hose Ends: Selection of the proper end fittings for the hose end application is essential to the proper operation and safe use of the hose and related equipment. Inadequate attention to the selection of the end fittings for your application can result in leaking or the hose ends blowing off the hose, leading to serious bodily injury or property damage. In order to avoid serious bodily injury or property damage resulting from selection of the wrong end fitting, you should carefully review the information in the Weatherhead Catalog W-HYOV-MC002-E.

⚠ WARNING

Coll-O-Crimp Hose, Hose Fittings and Assembly Equipment Compatibility: The Coll-O-Crimp Equipment

Package, Coll-O-Crimp End Fittings, and Coll-O-Crimp Hose have been engineered and designed as a complete hose assembly system. Each component of the Coll-O-Crimp hose assembly system is compatible with other Coll-O-Crimp components to which it relates. Component compatibility, along with the use of quality components, insures the production of reliable hose assemblies when assembled properly. The use or intermixing of fittings and hose not specifically engineered and designed for use with each other and Coll-O-Crimp equipment is not recommended and may result in the production of unsafe or unreliable hose assemblies. This can result in hose assembly leakage, hose separation or other failures which can cause serious bodily injury or property damage from spraying

fluids, flying projectiles, or other substances. Eaton's Weatherhead warranty is limited to apply only when Coll-O-Crimp end fittings and compatible Coll-O-Crimp hose are used with Coll-O-Crimp assembly equipment. **Nominal Crimp Diameter Measurement:** Please remove this chart and place near your Coll-O-Crimp equipment for reference. Measuring crimp diameters should be a part of the normal hose assembly procedure. To insure a proper crimp diameter reading, follow these steps.

1. Measure the diameter in the middle of crimped portion of the hose end.
2. Place the caliper in a position to allow a measurement across the pressed (flat) portion of the crimp.
3. See crimp diameters on following chart.

ET1000

HOSE TYPE	HOSE I.D. (IN.)	SKIVE TOOL	HOSE END PREFIX	COLLET PART #	SPACER RING COLOR	SPACER RING PART #	FLAT SIDE UP/DN	NOMINAL CRIMP DIA. (IN.)
H01704	1/4	N/A	04 'U'	T-400-2C	Yellow	T-400-62	UP	.580
H01706	3/8	N/A	06 'U'	T-400-3C	Black	T-400-10	UP	.785
H01708	1/2	N/A	08 'U'	T-400-4C	Silver	T-400-11	UP	.940
H01712	3/4	N/A	12 'U'	T-400-5C	Silver	T-400-11	UP	1.235
H01716	1	N/A	16 'U'	T-400-6C	Silver	T-400-11	UP	1.525
H01720	1-1/4	N/A	20 'U'	T-400-12	Black	T-400-10	DN	1.785
H03912	3/4	N/A	12 'U'	T-400-5C	Silver	T-400-11	UP	1.230
	3/4	N/R	12 'Z'	T-420-5CN	Tan	T-400-112	UP	1.401
H039H12	3/4	N/R	12 'Z'	T-420-5CN	Tan	T-400-112	UP	1.401
	1	N/A	16 'U'	T-400-6C	Silver	T-400-11	UP	1.520
H03916	1	N/R	16 'Z'	T-420-6CN	Black	T-400-10	DN	1.708
	1	N/R	16 'Z'	T-420-6CN	Black	T-400-10	DN	1.708
H03920	1-1/4	N/A	20 'U'	T-400-12	Black	T-400-10	DN	1.790
	1-1/4	N/R	20 'Z'	T-420-7CN	Black	T-400-10	DN	2.206
H039H20	1-1/4	N/R	20 'Z'	T-420-7CN	Black	T-400-10	DN	2.206
	1/4	N/A	04 'U'	T-400-2C	Black	T-400-10	DN	.560
H10404	1/4	N/A	04 'W'	T-400-40C	Black	T-400-10	DN	.664
	1/4	N/R	04 'Z'	ET400DC-M150S	Purple	ET1000SR-M100A	UP	.620
H10406	3/8	N/A	06 'U'	T-400-3C	Black	T-400-10	DN	.740

Note:
ET1000AR-001 or T-420-25 adapter die ring required when using T-400 series collets.

* Requires a pusher extension, part number ET1000C-0012, to be placed on top of spacer ring.

BK=Black **BU**=Blue **OR**=Orange
RD=Red **TN**=Tan **WH**=White
YW=Yellow **SV**=Silver **MG**=Magenta
GY=Gray **GR**=Green **BR**=Brown

Tooling Selector Chart

ET1000

HOSE TYPE	HOSE I.D. (IN.)	SKIVE TOOL	HOSE END PREFIX	COLLET PART #	SPACER RING COLOR	SPACER RING PART #	FLAT SIDE UP/DN	NOMINAL CRIMP DIA. (IN.)
	3/8	N/A	06 'W'	T-400-41C	Black	T-400-10	DN	.820
	3/8	N/R	06 'Z'	ET400DC-M195S	Purple	ET1000SR-M100A	UP	.785
H10408	1/2	N/A	08 'U'	T-400-4C	Black	T-400-10	DN	.870
	1/2	N/A	08 'W'	T-400-42C	Black	T-400-10	DN	.976
	1/2	N/R	08 'Z'	ET400DC-M230S	Black	T-400-10	DN	0.940
H10410	5/8	N/A	10 'U'	T-400-64C	Black	T-400-10	DN	1.000
H10410	5/8	N/A	10 'W'	T-420-85C	BK/WH	T-420-80R	UP	1.132
	5/8	N/R	10 'Z'	T-420-85C	Pink	ET420SR-M660A*	UP	1.055
H10412	3/4	N/A	12 'U'	T-400-5C	Black	T-400-10	DN	1.160
H10412	3/4	N/A	12 'W'	T-420-86C	BK/BU	T-420-82R*	UP	1.260
	3/4	N/R	12 'Z'	T-420-86C	Brown	ET420SR-M495A	UP	1.250
H10416	1	N/A	16 'U'	T-400-6C	Black	T-400-10	DN	1.450
	1	N/A	16 'W'	T-420-87C	BK/WH	T-420-80R	UP	1.587
	1	N/R	16 'Z'	ET420DC-M380S	Orange	T-420-29	UP	1.590
H10420	1-1/4	N/A	20 'U'	T-400-12	Black	T-400-10	DN	1.785
H10504	1/4	N/A	04 'U'	T-400-2C	Black	T-400-10	UP	.610
H10506	3/8	N/A	06 'U'	T-400-3C	Black	T-400-10	UP	.788
H10508	1/2	N/A	08 'U'	T-400-4C	Silver	T-400-11	UP	.940
H10512	3/4	N/A	12 'U'	T-400-5C	Silver	T-400-11	UP	1.232
H10516	1	N/A	16 'U'	T-400-6C	Silver	T-400-11	DN	1.435
H11404	1/4	N/A	04 'U'	T-400-2C	Green	T-400-37	UP	.520
H11406	3/8	N/A	06 'U'	T-400-3C	Green	T-400-37	UP	.695
H11408	1/2	N/A	08 'U'	T-400-4C	Green	T-400-37	UP	.830
H11504	1/4	N/A	04 'U'	T-400-2C	Black	T-400-10	UP	.610
H11506	3/8	N/A	06 'U'	T-400-3C	Black	T-400-10	UP	.788
H11508	1/2	N/A	08 'U'	T-400-4C	Silver	T-400-11	UP	.940
H11512	3/4	N/A	12 'U'	T-400-5C	Silver	T-400-11	UP	1.232
H11516	1	N/A	16 'U'	T-400-6C	Silver	T-400-11	UP	1.522
H11520	1-1/4	N/A	20 'U'	T-400-12	Silver	T-400-11	UP	1.862
H14504	1/4	N/A	04 'U'	T-400-2C	Green	T-400-37	UP	.520
	1/4	N/A	04 'W'	T-400-40C	BK/TN	T-400-46R	UP	.678
	1/4	N/R	04 'Z'	ET400DC-M150S	Purple	ET1000SR-M100A	UP	0.612
H145R04	1/4	N/R	04 'Z'	ET400DC-M150S	Purple	ET1000SR-M100A	UP	0.612
H14506	3/8	N/A	06 'U'	T-400-3C	Green	T-400-37	UP	.695
	3/8	N/A	06 'W'	T-400-41C	Green	T-400-37	UP	.782
	3/8	N/R	06 'Z'	ET400DC-M195S	Green	T-400-37	UP	0.775
H145R06	3/8	N/R	06 'Z'	ET400DC-M195S	Green	T-400-37	UP	0.775
H14508	1/2	N/A	08 'U'	T-400-4C	Yellow	T-400-62	DN	.870
	1/2	N/A	08 'W'	T-400-42C	Black	T-400-10	DN	.976
	1/2	N/R	08 'Z'	ET400DC-M230S	Purple	ET1000SR-M100A	UP	0.920
H145R08	1/2	N/R	08 'Z'	ET400DC-M230S	Purple	ET1000SR-M100A	UP	0.920
H14510	5/8	N/A	10 'U'	T-400-64C	Yellow	T-400-62	UP	1.010
	5/8	N/A	10 'W'	T-420-85C	Black	T-400-10	DN	1.149
	5/8	N/R	10 'Z'	T-420-85C	BK/GY	ET420SR-M255A	UP	1.115
H145R10	5/8	N/R	10 'Z'	T-420-85C	BK/GY	ET420SR-M255A	UP	1.115
H14512	3/4	N/A	12 'U'	T-400-5C	Yellow	T-400-62	DN	1.160
	3/4	N/A	12 'W'	T-420-86C	BK/OR	T-420-81R	UP	1.293
	3/4	N/R	12 'Z'	T-420-86C	Orange	T-420-29	UP	1.275
H145R12	3/4	N/R	12 'Z'	T-420-86C	Orange	T-420-29	UP	1.275
H14516	1	N/A	16 'U'	T-420-87C	BK/WH	T-420-80R	UP	1.587
	1	N/R	16 'Z'	ET420DC-M380S	BK/BU	T-420-82R*	UP	1.575
H145R16	1	N/R	16 'Z'	ET420DC-M380S	BK/BU	T-420-82R	UP	1.575
H14604	1/4	N/A	04 'U'	T-400-2C	Green	T-400-37	UP	.520
H14606	3/8	N/A	06 'U'	T-400-3C	Green	T-400-37	UP	.695
H14608	1/2	N/A	08 'U'	T-400-4C	Green	T-400-37	UP	.830
H19004	1/4	N/A	04 'W'	T-400-40C	Black	T-400-10	DN	.664
	1/4	N/R	04 'Z'	ET400DC-M150S	Purple	ET1000SR-M100A	UP	0.620

Note:
ET1000AR-001 or T-420-25 adapter die ring required when using T-400 series collets.

* Requires a pusher extension, part number ET1000C-0012, to be placed on top of spacer ring.

BK=Black **BU**=Blue **OR**=Orange
RD=Red **TN**=Tan **WH**=White
YW=Yellow **SV**=Silver **MG**=Magenta
GY=Gray **GR**=Green **BR**=Brown

Tooling Selector Chart

ET1000

HOSE TYPE	HOSE I.D. (IN.)	SKIVE TOOL	HOSE END PREFIX	COLLET PART #	SPACER RING COLOR	SPACER RING PART #	FLAT SIDE UP/DN	NOMINAL CRIMP DIA. (IN.)
H190H04	1/4	N/R	04 'Z'	ET400DC-M150S	Purple	ET1000SR-M100A	UP	0.620
H19006	3/8	N/A	06 'W'	T-400-41C	Black	T-400-10	DN	.820
	3/8	N/R	06 'Z'	ET400DC-M195S	Green	T-400-37	UP	0.770
H190H06	3/8	N/R	06 'Z'	ET400DC-M195S	Green	T-400-37	UP	0.770
H19008	1/2	N/A	08 'W'	T-400-42C	Black	T-400-10	DN	.976
	1/2	N/R	08 'Z'	ET400DC-M230S	Black	T-400-10	DN	0.940
H190H08	1/2	N/R	08 'Z'	ET400DC-M230S	Black	T-400-10	DN	0.940
H19010	5/8	N/A	10 'W'	T-420-85C	BK/WH	T-420-80R	UP	1.132
	5/8	N/R	10 'Z'	T-420-85C	Pink	ET420SR-M660A*	UP	1.055
H190H10	5/8	N/R	10 'Z'	T-420-85C	Pink	ET420SR-M660A	UP	1.055
H19012	3/4	N/A	12 'W'	T-420-86C	BK/BU	T-420-82R*	UP	1.260
	3/4	N/R	12 'Z'	T-420-86C	Brown	ET420SR-M495A	UP	1.250
H190H12	3/4	N/R	12 'Z'	T-420-86C	Brown	ET420SR-M495A	UP	1.250
H19016	1	N/A	16 'W'	T-420-87C	BK/WH	T-420-80R	UP	1.587
	1	N/R	16 'Z'	ET1000DC-M390S	Orange	T-420-29	UP	1.590
H190H16	1	N/R	16 'Z'	ET1000DC-M390S	Orange	T-420-29	UP	1.590
H19020	1-1/4	N/R	20 'Z'	ET420DC-M420S	Black	T-400-10	DN	1.800
H190H20	1-1/4	N/R	20 'Z'	ET420DC-M420S	Black	T-400-10	DN	1.800
H24504	1/4	N/A	04 'U'	T-400-2C	Yellow	T-400-62	DN	.560
H24504	1/4	N/A	04 'W'	T-400-40C	BK/TN	T-400-46R	UP	.678
	1/4	N/R	04 'Z'	ET400DC-M150S	Black	T-400-10	DN	.640
H245L04	1/4	N/R	04 'Z'	ET400DC-M150S	Black	T-400-10	DN	.640
H24506	3/8	N/A	06 'U'	T-400-3C	Yellow	T-400-62	DN	.740
	3/8	N/A	06 'W'	T-400-41C	Black	T-400-10	DN	.820
	3/8	N/R	06 'Z'	ET400DC-M195S	Tan	T-400-112	UP	.800
H245L06	3/8	N/R	06 'Z'	ET400DC-M195S	Tan	T-400-112	UP	.800
H24508	1/2	N/A	08 'U'	T-400-4C	Yellow	T-400-62	DN	.865
	1/2	N/A	08 'W'	T-400-42C	BK/TN	T-400-46R	UP	.993
	1/2	N/R	08 'Z'	ET400DC-M230S	Lt. Green	ET1000SR-M190D	UP	.975
H245L08	1/2	N/R	08 'Z'	ET400DC-M230S	Lt. Green	ET1000SR-M190D	UP	.975
H24510	5/8	N/A	10 'U'	T-400-64C	Yellow	T-400-62	UP	1.010
	5/8	N/A	10 'W'	T-420-85C	BK/WH	T-420-80R	UP	1.132
	5/8	N/R	10 'Z'	T-420-85C	BK/MG	ET400SR-M215A	UP	1.115
H245L10	5/8	N/R	10 'Z'	T-420-85C	BK/MG	ET400SR-M215A	UP	1.115
H24512	3/4	N/A	12 'U'	T-400-5C	Yellow	T-400-62	DN	1.160
	3/4	N/A	12 'W'	T-420-86C	BK/OR	T-420-81R	UP	1.293
	3/4	N/R	12 'Z'	T-420-86C	Brown	ET420SR-M495A	UP	1.245
H245L12	3/4	N/R	12 'Z'	T-420-86C	Brown	ET420SR-M495A	UP	1.245
H24516	1	N/A	16 'U'	T-400-6C	Yellow	T-400-62	Up	1.465
	1	N/A	16 'W'	T-420-87C	BK/WH	T-420-80R	UP	1.587
	1	N/R	16 'Z'	ET420DC-M380S	Brown	ET420SR-M495A	UP	1.565
H245L16	1	N/R	16 'Z'	ET420DC-M380S	Brown	ET420SR-M495A	UP	1.565
H24520	1-1/4	N/A	20 'U'	T-400-12	Yellow	T-400-62	DN	1.795
	1-1/4	N/R	20 'Z'	ET420DC-M480S	BK/BU	T-420-82R*	UP	1.900
H245L20	1-1/4	N/R	20 'Z'	ET420DC-M480S	BK/BU	T-420-82R	UP	1.900
H28004	1/4	N/A	04 'W'	T-400-40C	BK/TN	T-400-46R	UP	.678
	1/4	N/R	04 'Z'	ET400DC-M150S	Yellow	T-400-62	UP	.665
H28006	3/8	N/A	06 'W'	T-400-41C	Black	T-400-10	DN	.820
	3/8	N/R	06 'Z'	ET400DC-M195S	Black	T-400-10	DN	.815
H28008	1/2	N/A	08 'W'	T-400-42C	BK/TN	T-400-46R	UP	.992
	1/2	N/R	08 'Z'	ET400DC-M230S	Lt. Green	ET1000SR-M190D	UP	0.975
H28010	5/8	N/A	10 'W'	T-420-85C	BK/WH	T-420-80R	UP	1.132
	5/8	N/R	10 'Z'	T-420-85C	BK/GY	ET420SR-M255A	UP	1.115
H28012	3/4	N/A	12 'W'	T-420-86C	BK/OR	T-420-81R	UP	1.293
	3/4	N/R	12 'Z'	T-420-86C	Brown	ET420SR-M495A	UP	1.245
H28016	1	N/A	16 'W'	T-420-87C	BK/WH	T-420-80R	UP	1.587
	1	N/R	16 'Z'	ET420DC-M380S	Brown	ET420SR-M495A	UP	1.565

Note:
ET1000AR-001 adapter die ring required when using T-400 series collets.

* Requires a pusher extension, part number ET1000C-0012, to be placed on top of spacer ring.

BK=Black **BU**=Blue **OR**=Orange
RD=Red **TN**=Tan **WH**=White
YW=Yellow **SV**=Silver **MG**=Magenta
GY=Gray **GR**=Green **BR**=Brown

Tooling Selector Chart

ET1000

HOSE TYPE	HOSE I.D. (IN.)	SKIVE TOOL	HOSE END PREFIX	COLLET PART #	SPACER RING COLOR	SPACER RING PART #	FLAT SIDE UP/DN	NOMINAL CRIMP DIA. (IN.)
H28020	1-1/4	N/R	20 'Z'	ET420DC-M480S	BK/BU	T-420-82R*	UP	1.900
H29004	1/4	N/A	04 'W'	T-400-40C	Black	T-400-10	UP	.722
	1/4	N/R	04 'Z'	ET400DC-M150S	Lt. Green	ET1000SR-M190D	UP	.680
H290H04	1/4	N/R	04 'Z'	ET400DC-M150S	Lt. Green	ET1000SR-M190D	UP	.680
H29006	3/8	N/A	06 'W'	T-400-41C	BK/RD	T-400-47R	UP	.854
	3/8	N/R	06 'Z'	ET400DC-M195S	Yellow	T-400-62	UP	.835
H290H06	3/8	N/R	06 'Z'	ET400DC-M195S	Yellow	T-400-62	UP	0.835
H29008	1/2	N/A	08 'W'	T-400-42C	BK/RD	T-400-47R	UP	1.007
	1/2	N/R	08 'Z'	ET400DC-M230S	Black	T-400-10	UP	0.990
H290H08	1/2	N/R	08 'Z'	ET400DC-M230S	Black	T-400-10	UP	0.990
H29010	5/8	N/A	10 'W'	T-420-85C	Black	T-400-10	DN	1.149
	5/8	N/R	10 'Z'	T-420-85C	BK/WH	T-420-80R	UP	1.130
H290H10	5/8	N/R	10 'Z'	T-420-85C	BK/WH	T-420-80R	UP	1.130
H29012	3/4	N/A	12 'W'	T-420-86C	Black	T-400-10	DN	1.317
	3/4	N/R	12 'Z'	T-420-86C	BK/GY	ET420SR-M255A	UP	1.280
H290H12	3/4	N/R	12 'Z'	T-420-86C	BK/GY	ET420SR-M255A	UP	1.280
H29016	1	N/A	16 'W'	T-420-87C	Black	T-400-10	DN	1.607
	1	N/R	16 'Z'	ET420DC-M380S	Black	T-400-10	DN	1.630
H290H16	1	N/R	16 'Z'	ET420DC-M380S	Black	T-400-10	DN	1.630
H29020	1-1/4	N/R	20 'Z'	ET1000DC-M475S	Silver	T-400-11	DN	2.000
	1-1/4	N/R	20 'Z'	ET420DC-M480S	Black	T-400-10	DN	1.960
H290H20	1-1/4	N/R	20 'Z'	ET1000DC-M475S	Silver	T-400-11	UP	2.000
H32406	3/8	N/A	06 'U'	T-400-3C	Black	T-400-10	UP	.785
H32504	1/4	N/A	04 'U'	T-400-2C	Black	T-400-10	UP	.610
H32506	3/8	N/A	06 'U'	T-400-3C	Black	T-400-10	UP	.795
H32508	1/2	N/A	08 'U'	T-400-4C	Yellow	T-400-62	UP	.885
H32512	3/4	N/A	12 'U'	T-400-5C	Black	T-400-10	UP	1.215
H32516	1	N/A	16 'U'	T-400-6C	Silver	T-400-11	UP	1.525
H34504	1/4	N/R	04 'Z'	ET400DC-M150S	Tan	T-400-112	UP	0.625
H34506	3/8	N/R	06 'Z'	ET400DC-M195S	Green	T-400-37	UP	0.775
H34508	1/2	N/R	08 'Z'	ET400DC-M230S	Black	T-400-10	DN	0.940
H35006	3/8	N/A	06 'U'	T-400-3C	Yellow	T-400-62	DN	.740
	3/8	N/R	06 'Z'	ET400DC-M195S	Black	T-400-10	DN	0.815
H35008	1/2	N/A	08 'U'	T-400-4C	Yellow	T-400-62	DN	.865
H35008	1/2	N/R	08 'Z'	ET400DC-M230S	Lt. Green	ET1000SR-M190D	UP	0.975
H35010	5/8	N/R	10 'Z'	T-420-85C	BK/WH	T-420-80R	UP	1.130
H40006				ET400DC-M195S	Yellow	T-400-62	UP	0.835
H40008				ET400DC-M230S	Black	T-400-10	UP	0.990
H40010	5/8	N/R	10 'Z'	T-420-85C	BK/WH	T-420-80R	UP	1.129
H40012	3/4	N/R	12 'Z'	T-420-86C	BK/GY	ET420SR-M255A	UP	1.286
H42104	1/4	N/R	04 'Z'	ET400DC-M150S	BK/RD	T-400-47R	UP	0.665
H42106	3/8	N/R	06 'Z'	ET400DC-M195S	Yellow	T-400-62	UP	0.835
H42504	1/4	N/A	04 'U'	T-400-2C	Black	T-400-10	UP	.610
	1/4	N/A	04 'W'	T-400-40C	Black	T-400-10	UP	.722
	1/4	N/R	04 'Z'	ET400DC-M150S	Yellow	T-400-62	UP	0.665
H42506	3/8	N/A	06 'U'	T-400-3C	Black	T-400-10	UP	.795
	3/8	N/A	06 'W'	T-400-41C	BK/RD	T-400-47R	UP	.854
	3/8	N/R	06 'Z'	ET400DC-M195S	Yellow	T-400-62	UP	0.835
H42508	1/2	N/A	08 'U'	T-400-4C	Black	T-400-10	UP	.915
	1/2	N/A	08 'W'	T-400-42C	BK/RD	T-400-47R	UP	1.007
	1/2	N/R	08 'Z'	ET400DC-M230S	Black	T-400-10	UP	0.990
H42510	5/8	N/A	10 'U'	T-400-64C	Black	T-400-10	UP	1.050
	5/8	N/A	10 'W'	T-420-85C	BK/WH	T-420-80R	UP	1.132
	5/8	N/R	10 'Z'	T-420-85C	BK/WH	T-420-80R	UP	1.130
H42512	3/4	N/A	12 'U'	T-400-5C	Black	T-400-10	UP	1.205
	3/4	N/A	12 'W'	T-420-86C	Black	T-400-10	DN	1.317
	3/4	N/R	12 'Z'	T-420-86C	BK/GY	ET420SR-M255A	UP	1.280

Note:
ET1000AR-001 adapter die ring required when using T-400 series collets.

* Requires a pusher extension, part number ET1000C-0012, to be placed on top of spacer ring.

BK=Black **BU**=Blue **OR**=Orange
RD=Red **TN**=Tan **WH**=White
YW=Yellow **SV**=Silver **MG**=Magenta
GY=Gray **GR**=Green **BR**=Brown

Tooling Selector Chart

ET1000

HOSE TYPE	HOSE I.D. (IN.)	SKIVE TOOL	HOSE END PREFIX	COLLET PART #	SPACER RING COLOR	SPACER RING PART #	FLAT SIDE UP/DN	NOMINAL CRIMP DIA. (IN.)
H42516	1	N/A	16 'W'	T-420-87C	Black	T-400-10	DN	1.607
	1	N/A	16 'U'	T-400-6C	Silver	T-400-11	UP	1.525
	1	N/R	16 'Z'	ET420DC-M380S	Black	T-400-10	DN	1.630
H42520	1-1/4	N/A	20 'U'	T-400-12	Black	T-400-10	UP	1.850
	1-1/4	N/R	20 'Z'	ET420DC-M480S	Black	T-400-10	DN	1.960
H43006	3/8	N/A	43006 'U'	ET1000DC-M230S	Red	T-400-38	UP	.896
H430R06	3/8	N/A	430 'U'	ET1000DC-M230S	Red	T-400-38	UP	.896
H43008	1/2	N/A	43008 'U'	T-420-4CN	Black	ET1000SR-M265D	DN	1.150
H430R08	1/2	N/A	430 'U'	T-420-4CN	Black	ET1000SR-M265D	DN	1.150
H43010	5/8	N/A	43010 'U'	ET1000DC-M295S	Orange	T-420-29	UP	1.406
H430R10	5/8	N/A	430 'U'	ET1000DC-M295S	Orange	T-420-29	UP	1.406
H43012	3/4	N/A	43012 'U'	T-420-5CN	Black	ET1000SR-M265D	DN	1.705
H430R12	3/4	N/A	430 'U'	T-420-5CN	Black	ET1000SR-M265D	DN	1.705
H54504	1/4	N/A	04 'U'	T-400-2C	Yellow	T-400-62	DN	.560
H54506	3/8	N/A	06 'U'	T-400-3C	Green	T-400-37	UP	.695
H54508	1/2	N/A	08 'U'	T-400-4C	Yellow	T-400-62	DN	.865
H54510	5/8	N/A	10 'U'	T-400-64C	Yellow	T-400-62	UP	1.010
H54512	3/4	N/A	12 'U'	T-400-5C	Yellow	T-400-62	DN	1.155
H54504	1/4	N/A	04 'W'	T-400-40C	Black	T-400-10	DN	.664
H54506	3/8	N/A	06 'W'	T-400-41C	Black	T-400-10	DN	.820
H54508	1/2	N/A	08 'W'	T-400-42C	BK/TN	T-400-46R	UP	.992
H54510	5/8	N/A	10 'W'	T-420-85C	BK/WH	T-420-80R	UP	1.132
H54512	3/4	N/A	12 'W'	T-420-86C	BK/OR	T-420-81R	UP	1.293
H54516	1	N/A	16 'W'	T-420-87C	BK/WH	T-420-80R	UP	1.587
H9610-6	3/8	N/R	06 'Z'	ET400DC-M195S	Purple	ET1000SR-M100A	UP	.785
H9610-8	1/2	N/R	08 'Z'	ET400DC-M230S	Black	T-400-10	DN	.940

Note:
ET1000AR-001 adapter die ring required when using T-400 series collets.

* Requires a pusher extension, part number ET1000C-0012, to be placed on top of spacer ring.

BK=Black **BU**=Blue **OR**=Orange
RD=Red **TN**=Tan **WH**=White
YW=Yellow **SV**=Silver **MG**=Magenta
GY=Gray **GR**=Green **BR**=Brown

Eaton's Weatherhead Hose and Fitting Assembly Product Warning

Flexible hose lines offer many advantages over rigid tubing including routing ease, vibration absorption, sound deafening and the ability to accommodate movement of connected components. However, hose lines require caution in use not only to provide long service, but also to guard against potentially dangerous failure.

WARNING

Eaton's Weatherhead fitting tolerances are engineered to match Eaton's Weatherhead hose tolerances. The use of Weatherhead fittings on hose supplied by other manufacturers and/or the use of Weatherhead hoses with fittings supplied by other manufacturers may result in the production of unreliable and unsafe hose assemblies and is neither recommended nor authorized by Eaton Corporation or any of its affiliates or subsidiaries.

WARNING

Application considerations must be observed in selecting appropriate components for the application of these products contained herein. The failure to follow the recommendations set forth in this catalog may result in an unstable application which may result in serious personal injury or property damage.

EATON CORPORATION OR ANY OF ITS AFFILIATES OR SUBSIDIARIES SHALL NOT BE SUBJECT TO AND DISCLAIMS ANY OBLIGATIONS OR LIABILITIES (INCLUDING BUT NOT LIMITED TO ALL CONSEQUENTIAL, INCIDENTAL AND CONTINGENT DAMAGES) ARISING FROM TORT CLAIMS (INCLUDING WITHOUT LIMITATION NEGLIGENCE AND STRICT LIABILITY) OR OTHER THEORIES OF LAW WITH RESPECT TO ANY HOSE ASSEMBLIES NOT MANUFACTURED FROM GENUINE EATON WEATHERHEAD HOSE FITTINGS, WEATHERHEAD HOSE, AND EATON APPROVED EQUIPMENT, AND IN CONFORMANCE WITH EATON'S WEATHERHEAD PROCESS AND PRODUCT INSTRUCTIONS FOR EACH SPECIFIC HOSE ASSEMBLY.

Failure to follow these processes and product instructions and limitations could lead to premature hose assembly failures resulting in property damage, serious injury or death.

Routing

If the user follows the recommendations on hose line routing and installation as provided for herein, improved safety and longer service life of any hose installation will result.

Eaton
Hydraulics Operations USA
14615 Lone Oak Road
Eden Prairie, MN 55344
USA
Tel: 952-937-9800
Fax: 952-294-7722
www.hydraulics.eaton.com

Eaton
Hydraulics Operations Europe
Route de la Longeraie 7
1110 Morges
Switzerland
Tel: +41 (0) 21 811 4600
Fax: +41 (0) 21 811 4601

Eaton
Hydraulics Operations Asia Pacific
11th Floor Hong Kong New World Tower
300 Huaihai Zhong Road
Shanghai 200021
China
Tel: 86-21-6387-9988
Fax: 86-21-6335-3912



Weatherhead

© 2007 Eaton Corporation
All Rights Reserved
Printed in USA
Document No. W-HOOV-TM001-E2
Supersedes W-HOOV-TM001-E1
September 2007